



EVALUATION OF SUBSURFACE PRODUCED GAS INJECTION

Final Report

Prepared for:

Karlene Fine

North Dakota Industrial Commission
State Capitol, 14th Floor
600 East Boulevard Avenue, Department 405
Bismarck, ND 58505-0840

Contract No.: G-000-004

Prepared by:

Bethany A. Kurz
Todd Jiang
Chad A. Wocken
Wesley D. Peck
Steven M. Schlasner
Benjamin S. Oster
Nicholas W. Bosshart
T. Austin McRae
Charles D. Gorecki
John A. Harju
Edward N. Steadman

Energy & Environmental Research Center
University of North Dakota
15 North 23rd Street, Stop 9018
Grand Forks, ND 58202-9018

EERC DISCLAIMER

LEGAL NOTICE This research report was prepared by the Energy & Environmental Research Center (EERC), an agency of the University of North Dakota, as an account of work sponsored by the North Dakota Industrial Commission. Because of the research nature of the work performed, neither the EERC nor any of its employees makes any warranty, express or implied, or assumes any legal liability or responsibility for the accuracy, completeness, or usefulness of any information, apparatus, product, or process disclosed or represents that its use would not infringe privately owned rights. Reference herein to any specific commercial product, process, or service by trade name, trademark, manufacturer, or otherwise does not necessarily constitute or imply its endorsement or recommendation by the EERC.

NDIC DISCLAIMER

This report was prepared by the EERC pursuant to an agreement partially funded by the Industrial Commission of North Dakota, and neither the EERC nor any of its subcontractors nor the North Dakota Industrial Commission nor any person acting on behalf of either:

- (A) Makes any warranty or representation, express or implied, with respect to the accuracy, completeness, or usefulness of the information contained in this report, or that the use of any information, apparatus, method, or process disclosed in this report may not infringe privately owned rights; or
- (B) Assumes any liabilities with respect to the use of, or for damages resulting from the use of, any information, apparatus, method, or process disclosed in this report.

Reference herein to any specific commercial product, process, or service by trade name, trademark, manufacturer, or otherwise does not necessarily constitute or imply its endorsement, recommendation, or favoring by the North Dakota Industrial Commission. The views and opinions of authors expressed herein do not necessarily state or reflect those of the North Dakota Industrial Commission.

TABLE OF CONTENTS

LIST OF FIGURES	iii
LIST OF TABLES	iv
EXECUTIVE SUMMARY	v
INTRODUCTION	1
BACKGROUND – FLARING IN THE BAKKEN	2
Flare Gas Quality	5
Flare Gas Quantity	5
Flare Gas Transience.....	6
SUBSURFACE GAS INJECTION	8
SIMULATION OF PRODUCED GAS INJECTION INTO THE BROOM CREEK	11
Summary of Simulation Results	16
ASSOCIATED GAS INJECTION SURFACE FACILITY DESCRIPTION AND COST	20
Surface Facility System Description and Design	20
Gas Compression System Description	21
Process Description	21
Cost	21
Stored Gas Recovery System	22
Process Description	22
Cost	22
Overall Capital Equipment Cost Summary	23
Additional Cost Considerations for Geologic Gas Storage.....	24
Economic Benefit	24
ALTERNATIVE TARGETS FOR PRODUCED GAS INJECTION	26
Potential Williston Basin Injection Targets	29
Potential Gas Injection Targets in Saline Zones or Conventional Oil and Gas Reservoirs.....	31
Deadwood Formation.....	31
Black Island Formation.....	32
Red River Formation.....	33
Winnipegosis Formation	33
Duperow Formation	34
Madison Group.....	34
Amsden Formation	34
Kibbey Formation.....	35
Potential Unconventional Reservoir Injection Targets.....	35

Continued . . .

TABLE OF CONTENTS (continued)

CONSIDERATIONS FOR PRODUCED GAS STEWARDSHIP35

- Logistical, Economic, and Legal Considerations36
 - Scale and Duration.....36
 - Planning and Timing.....36
 - Competing Alternative Gas Use Technologies36
 - Gas Contracts with Midstream Companies.....37
- Regulatory Considerations37
 - Storage in DSFs.....38
 - Produced Gas Injection into Conventional Oil Reservoirs40
 - Produced Gas Injection into the Source Formation.....40

DISCUSSION AND CONCLUSIONS.....41

FUTURE WORK.....43

REFERENCES44

SIMULATION OF PRODUCED GAS INJECTION INTO THE BROOM
CREEK FORMATION Appendix A

LIST OF FIGURES

1	Illustration of increasing Bakken–Three Forks GOR from January 2010 to September 2018	2
2	Example gathering infrastructure	3
3	Natural gas processing	4
4	Average gas decline curves for Bakken and Three Forks wells based on county	6
5	Illustration of the transient nature of flaring	7
6	Distribution of U.S. natural gas storage reservoirs by type	10
7	Map showing the location of the geologic and simulation model	12
8	Map view of the simulation model showing the injection well locations and depth of the Broom Creek Formation top.....	13
9	Gas recovery factor for Cases 22–24	15
10	Water and gas production rates from Well 1 for Cases 22–24.....	15
11	Cross-sectional view and aerial view of one simulated gas plume after 2 years of injection at 10 MMscf/day	17
12	Gas and water production rates following 2 years of gas injection and gas recovery factors for a cyclic gas injection and recovery scenario	18
13	Types of structural and stratigraphic geologic traps	27
14	Major geologic structures within the Williston Basin of North Dakota	28
15	Little Knife Field: structural contour map of the Mission Canyon top and struture contour map of the Broom Creek top	29
16	North Dakota stratigraphic column highlighting potential gas storage target formations ...	30
17	Map of conventional oil fields, including unitized fields, that could serve as potential gas injection targets	32
18	Produced gas injection scenarios	37
19	Visual representation of pore space amalgamation considerations with respect to landowners within a given gas storage project area	39

LIST OF TABLES

1	Summary of Total Capacity and Maximum Daily Gas Output of Commercial Gas Storage Sites Within Aquifers, Depleted Oil and Gas Fields, and Salt Domes	8
2	Summary of Storage Parameters by Storage Reservoir Type for Commercial Gas Storage Sites Within the United States	9
3	Summary of Storage Parameters and Storage Reservoir Type for Commercial Gas Storage Sites Within the United States	9
4	Produced Gas Composition from a Typical Bakken Well	12
5	Simulation Scenarios for Cases Constraining Gas Production Rate	14
6	Summary of Operating Conditions for Gas Compression and Gas Recovery Systems	21
7	Gas Compression System Cost Estimate	22
8	Gas Injection System Capital Cost Estimates	22
9	Gas Recovery and Water Injection System Cost Estimates	23
10	Combined Capital Equipment Costs for Geologic Storage of Associated Gas.....	23

EVALUATION OF SUBSURFACE PRODUCED GAS INJECTION

EXECUTIVE SUMMARY

Extraction of oil and gas from the Bakken petroleum system (Bakken) has dramatically increased over the past decade without commensurate augmentation of gas capture infrastructure, which has resulted in increased flaring of produced gas. The North Dakota Industrial Commission (NDIC) has worked with industry to establish gas capture requirements to reduce the volume of flared gas. However, in the face of increasing production, industry is experiencing challenges in meeting the current gas capture requirement of 88%. Basinwide estimates of voluntarily curtailed oil production range from 50,000 to 80,000 bbl/day as oil companies are faced with the challenges of meeting gas capture requirements.

The Energy & Environmental Research Center (EERC) conducted a 3-month effort to investigate options to reduce flaring that could help to unlock curtailed oil production. The prime focus of this effort was to evaluate the feasibility of produced gas injection and storage into the Broom Creek Formation or other subsurface targets to help alleviate flaring where pipeline capacity is limited, including in both hydrocarbon-bearing and saline formations. Technical, economic, and regulatory aspects associated with injection of produced gas into the subsurface were assessed. A case study using the Broom Creek Formation, a saline saturated sandstone formation, was constructed to illustrate the concept and evaluate the formation's potential as a produced gas storage target. Recognizing that the geologic extent of the Broom Creek does not include the northern portions of the core Bakken production area, alternative subsurface storage targets were also considered.

In this assessment, an assumption was made that gas injection would occur in conjunction with production at a drill spacing unit (DSU) or at an intermediate gathering location. Two injection rates were considered with these assumptions: 10 and 30 MMscf/day. The 10-MMscf/day scenario represents an achievable gas production rate from a single DSU, assuming multiple wells operating early in their production life. Furthermore, 10 MMscf/day of gas injection can be achieved with one or two skid-mounted compressors, providing some economy of scale while able to be operated within the footprint of a production location. The 30-MMscf/day scenario represents a larger gas volume, which may be achievable downstream of a series of DSUs at an intermediate gathering location. The larger injection scenario provides some economy-of-scale advantages but results in increased accounting challenges due to the contractual obligations of commingled gas within the gas-gathering system.

A geologic model of the Broom Creek Formation was used to simulate injection of produced gas. The two gas injection rates of 10 and 30 MMscf/day were evaluated over injection periods of 6 months and 2 years. Several gas recovery scenarios were evaluated, including immediate recovery after injection as well as recovery after 1, 3, and 5 years following injection. Recovery factors generated from the various simulation cases ranged from 25% to 74% after 5 years of gas recovery. The reservoir simulation scenarios also generated estimates of the volumes of water that were coproduced during gas recovery. Maximum water production rates ranged from 200 to 10,000 bbl/day, depending on the reservoir model assumptions. The best gas recovery factors occurred in the scenarios with moderate to higher water production rates, which highlights the need to consider produced water-handling options and costs.

A high-level economic evaluation was performed using the Broom Creek case study. The estimated capital costs ranged from \$15.7 million for the 10-MMscf/day gas injection scenario to \$34.5 million for the 30-MMscf/day scenario, an injection cost of \$2.15/Mcf based on the volume

of gas injected over a 2-year period at a rate of 10 MMscf/day. The primary consideration and expense associated with collection and handling of produced gas for subsurface injection is compression. The injection of rich gas to potential subsurface injection targets requires compression pressures ranging from 3000 to 4000 psi. Other costs were considered, including injection well drilling and installation, operation of the surface facilities for gas injection and recovery, and produced water handling.

The estimated benefit of subsurface produced gas storage, if used proactively to allow for additional well development on DSUs with limited gas capture pipeline capacity, could be as high as \$200 million. This was based on the value of the oil produced from wells that would otherwise have been delayed in development or been forced to curtail oil production.

From a regulatory standpoint, several factors need consideration if produced gas were to be injected into the subsurface. In the Broom Creek case study, key considerations include compensation to surface owners for their pore space, timing of royalty payments to mineral owners (preinjection or postrecovery and sale), and ownership of unrecovered gas remaining in the subsurface. Because injection of produced gas into a saline formation has not yet occurred in North Dakota, regulatory clarity for some of these aspects may not yet exist. An important legal aspect is the nature of the contracts between producers and midstream service providers, which could affect the volume and timing of gas available for subsurface storage.

Although the evaluated case study was focused on injection of produced gas into the Broom Creek Formation, other potential subsurface gas storage targets exist in the Williston Basin that occur beneath the entire core Bakken area and/or may offer opportunities for EOR. Technical, economic, and regulatory aspects for alternative storage formations were reviewed. There are several advantages to produced gas injection into hydrocarbon-bearing formations, including demonstrated ability of the formation to retain hydrocarbons, potential for enhanced oil recovery and associated revenue from oil sales, reservoir pressure maintenance, and potential mitigation of issues associated with pore space ownership.

Based on the results of this effort, cyclic periods of gas injection and recovery into an established gas storage target within the Broom Creek at a DSU level could be a cost-effective option to enable additional well development and production from well pads that have limited gas capture infrastructure. In areas where the DSU is in juxtaposition with another subsurface target or the Broom Creek is not present, the injection of produced gas into an oil and gas reservoir may be a viable technical and economic option, without the complications of regulatory uncertainty over pore space ownership that arise with injection into saline aquifers.

Additional work is needed to evaluate the benefits of gas injection into hydrocarbon-bearing targets with respect to gas recovery efficiency, incremental oil recovery and reservoir pressure maintenance and to assess the economic and regulatory aspects of the approach. The concept of subsurface gas injection should also be evaluated in relation to other allowable gas capture approaches, including wellsite NGL recovery, gas-fired electrical generation, or production of fuels and chemicals from stranded gas. Finally, a detailed site-specific analysis will be needed to assess the actual technical and economic implications for a particular real-world scenario. There are many factors that impact the viability of any alternative gas use option, and site-specific conditions vary widely across the Bakken. Stranded gas volumes, duration of gas availability, contract conditions with midstream gas processors, and a variety of options that impact an operator's gas capture requirements (gas capture carryover credits, compressed and liquefied natural gas credits, 60-day initial production exemptions, stranded gas designation, and force majeure exemptions) are operator- and location-specific and must be considered when evaluating the viability of alternate gas use.

EVALUATION OF SUBSURFACE PRODUCED GAS INJECTION

INTRODUCTION

The Bakken petroleum system (Bakken) in the Williston Basin of central North America is an unconventional tight oil play with oil-in-place estimates in the hundreds of billions of barrels (Nordeng and Helms, 2010). The Bakken includes both the Bakken and underlying Three Forks Formations. Oil production from the Bakken has rapidly expanded from approximately 340,000 barrels per day (bbl/day) in September 2010 to 1.4 million barrels per day (MMbbl/day) as of September 2018 (North Dakota Industrial Commission, 2018c). As oil production has increased, so too has the volume of coproduced gas, also referred to as associated gas. Gas production rapidly increased from an average of approximately 340 million standard cubic feet per day (MMscf/day) in January 2010 to an average of 2500 MMscf/day in September 2018 (North Dakota Industrial Commission, 2018c).

The rapid increase of oil and gas production from the Bakken has resulted in significant investment in infrastructure to transport oil and gas from the wellsite to market. For oil, this infrastructure includes tankage, truck-loading/unloading terminals, and pipelines. Associated gas cannot be stored in tanks so the process relies on gas-gathering pipelines and gas compressors to transport the gas to centralized gas-processing facilities where it can be separated into marketable products. Gas that cannot enter a gathering pipeline will be flared at the wellsite to avoid direct release to the environment. Factors that may contribute to gas flaring include a lack of gas-gathering pipelines to a wellsite, insufficient capacity of gas-gathering infrastructure, or temporary upset of gas gathering and/or processing for maintenance or other operational issues.

Associated gas is a valuable resource, and there is a strong desire by all stakeholders—oil companies, midstream gas companies, mineral owners, and the state of North Dakota—to minimize waste and extract value from this resource. To encourage a reduction in the volume of flared gas, the North Dakota Industrial Commission (NDIC) worked with industry to establish gas capture requirements, which, if not met, could result in oil production restrictions imposed on individual operators. However, in the face of increasing production, industry is struggling to meet the current state gas capture requirement of 88%. Based on gas capture numbers from November 2018, the estimated volume of curtailed oil production because of industry's inability to meet gas capture requirements ranged from 50,000 to 80,000 bbl/day. At oil prices of \$59/bbl, the value of the curtailed oil ranges from \$3 to \$4.7 million per day.

One approach being considered to help alleviate flaring is reinjection of produced gas into the subsurface. Several subsurface injection targets exist in the Williston Basin of North Dakota, including both hydrocarbon- and non-hydrocarbon-bearing formations. To evaluate the feasibility of this concept, the Energy & Environmental Research Center (EERC) conducted a 3-month study to assess the technical, economic, and regulatory aspects associated with reinjection of produced gas into the subsurface. To illustrate the concept, the EERC evaluated a case study using the Broom Creek Formation, a non-hydrocarbon-bearing saline formation that occurs at an average depth of approximately 7400 feet, as a produced gas storage target. The various geologic and engineering aspects of the concept were evaluated based on reservoir properties and a variety of assumed

operating conditions. Reservoir simulation of produced gas injection into the Broom Creek was conducted to assess the injectivity of the formation, injected gas plume extents, and gas recovery efficiencies. The regulatory and economic aspects of the concept were also assessed, including areas where regulatory clarity is needed for the concept to move forward. Lastly, in addition to the Broom Creek Formation, other potential injection targets were described and the benefits and/or constraints associated with each were evaluated.

This report discusses the details of the EERC study, including key results, conclusions, and recommendations for further work.

BACKGROUND – FLARING IN THE BAKKEN

Production of North Dakota’s oil brings with it large quantities of associated gas. As of September 2018, for every barrel of oil produced in the Bakken, 1.9 Mscf of gas was produced, and gas:oil ratios (GORs) have exhibited an increasing trend since January 2010 (Figure 1). While oil is stored in tanks on-site until it can be transported from the wellsite by pipeline or truck, the associated gas, cannot be stored easily and is typically “gathered” via small, low-pressure pipelines. An example of gathering infrastructure for oil and gas production is illustrated in

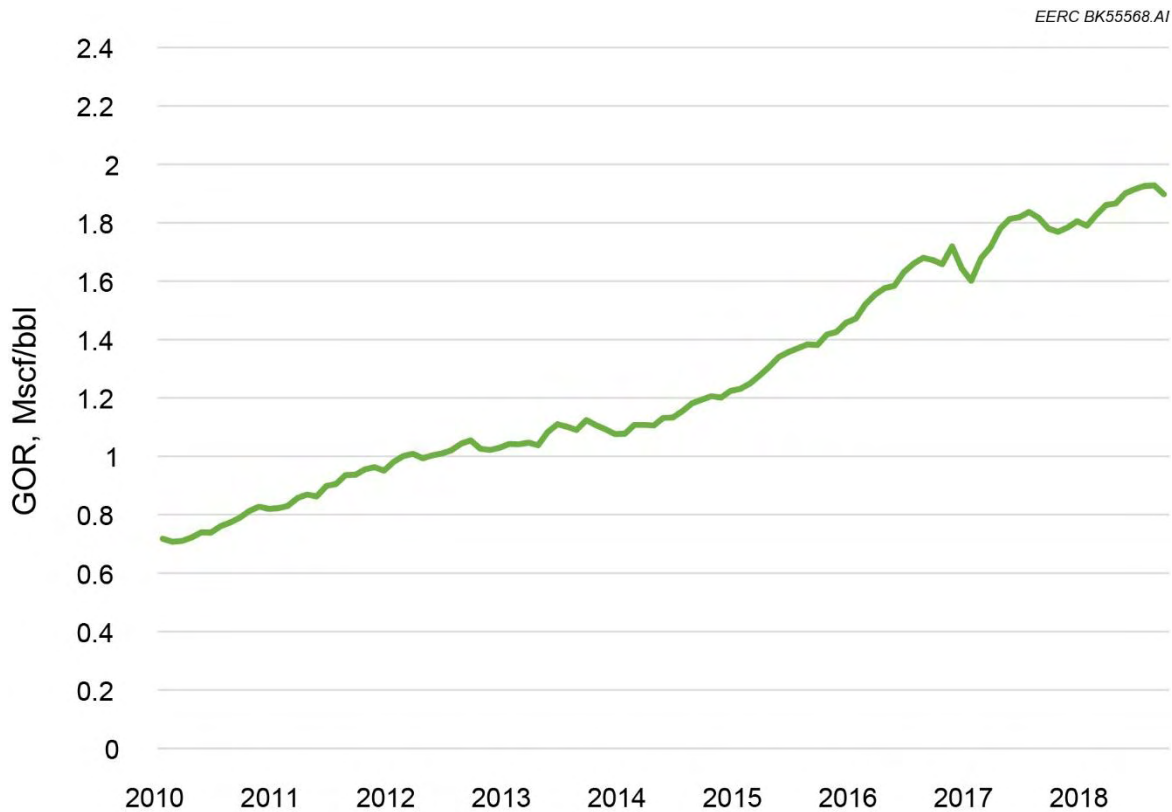
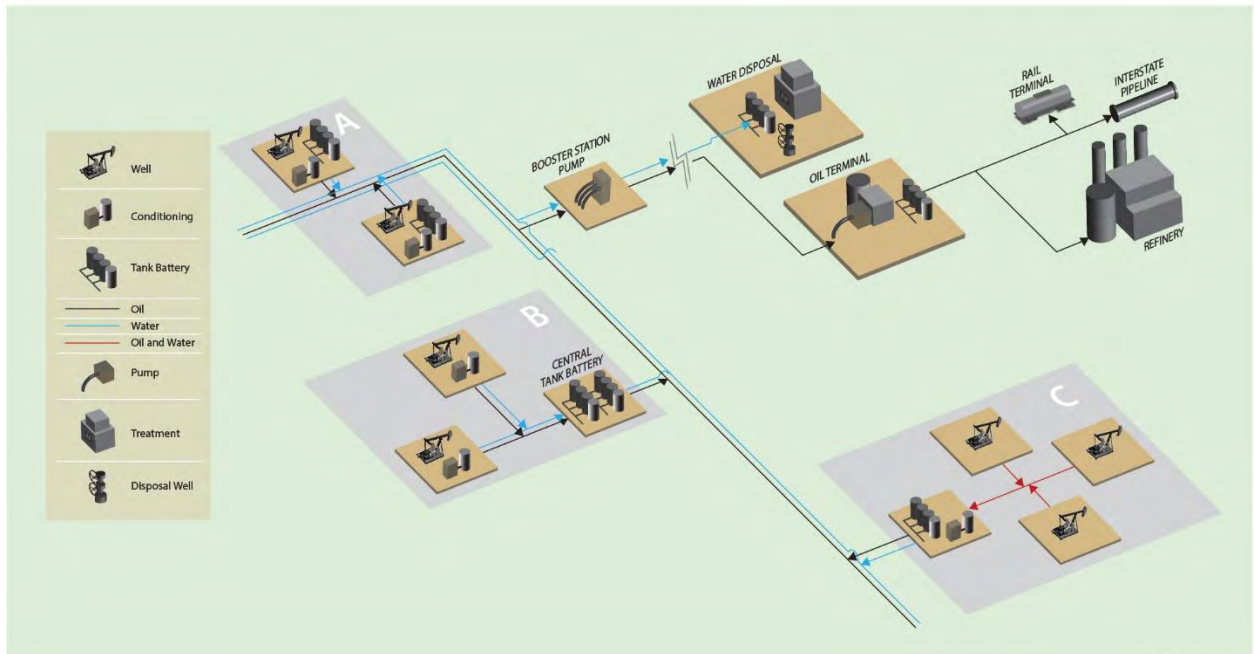

Figure 1. Illustration of increasing Bakken–Three Forks GOR from January 2010 to September 2018 (developed with data from the NDIC Web site, www.dmr.nd.gov/oilgas/).

Figure 2. This associated gas is transported to large gas-processing facilities where the methane and some ethane (natural gas) is separated from the various other gases, as shown in Figure 3. The other gases include propane, butane, pentane, and small amounts of hexane and heptane and are called NGLs. These can be marketed for further processing in the petrochemical industry.

The NDIC Oil and Gas Division implements and enforces oil- and gas-related regulations. Typically, these regulations allow oil production to occur at varying rates during the first several months of operations to determine production rates. During these early months of production, gas can be flared while production data are collected to assess the viability and determine gas-gathering capacity requirements. Following this exemption period, production may be restricted if statewide gas capture goals are not met. NDIC Order No. 24665 defines a graduated set of gas capture targets aimed at reducing associated gas flaring through 2020. As of November 1, 2018, the statewide gas capture target is 88% and is scheduled to increase to 91% beginning November 1, 2020. In addition to connecting produced gas to gas-gathering pipelines, NDIC Order 24665 Policy/Guidance Version 112018 (www.dmr.nd.gov/oilgas/12018GuidancePolicyNorthDakotaIndustrialCommissionorder24665_2/pdf) identifies acceptable alternate uses of gas that help reduce flaring include electrical generation, wellsite NGL recovery, compression and/or liquefaction of natural gas for use as a generator or transportation fuel, conversion to a chemical or fuel, value-added processes that reduce the volume or intensity of the flare by greater than 60%, or reinjection of the associated gas into a geologic formation for temporary storage.



EERC BK55569.AI

Figure 2. Example gathering infrastructure. Configuration A represents well pumps, conditioning equipment, and tankage on a well pad. Alternate Configuration B represents well pumps and conditioning on the well pad, with fluids stored on a separate central tank battery. Configuration C represents only well pumps on the wellsite, with fluid conditioning and tankage on a centralized conditioning and storage location.

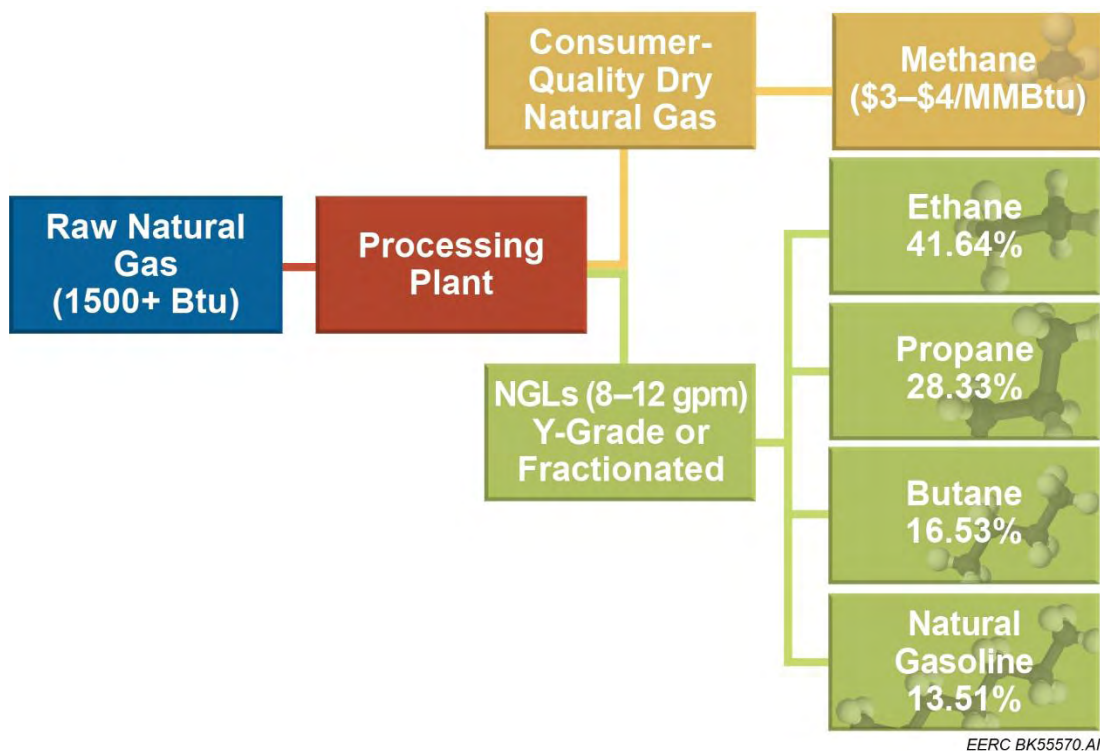

Figure 3. Natural gas processing (NGLs are natural gas liquids).

In general, the preferred fate of associated gas is to gather it from wellsites using gas-gathering pipelines for subsequent processing at gas-processing plants. These plants aggregate associated gas from multiple wellsites, remove contaminants like H₂S, and separate the hydrocarbons into marketable products including pipeline-quality natural gas (methane and ethane), liquefied petroleum gas (LPG), and NGLs. Unfortunately, the rapid increase in oil production and growing GOR, extremely high initial gas production from multiwell pads as well as challenges with installation of gas-gathering infrastructure (short construction season, pipeline right-of-way approval, and large geographic area) have contributed to areas in which gas-gathering and processing capacity cannot accommodate all of the gas produced. Work is ongoing to further expand gas-gathering and processing infrastructure to help meet gas capture targets, but current production forecasts (North Dakota Pipeline Authority) indicate that alternate gas use/management options may be needed for the near future to help mitigate gas flaring.

A survey of alternative gas use technologies entitled “End-Use Technology Study – An Assessment of Alternative Uses for Associated Gas” was prepared by the EERC and is available for download at www.undeerc.org/flaring_solutions/Files-Reports.aspx. This survey contains a description of the conditions that contribute to gas flaring and many of the factors that should be considered when assessing gas use options upstream or in place of traditional gas-processing infrastructure. These factors are important and formed the basis for many of the assumptions used to perform this technical and economic analysis of associated gas injection and storage in geologic formations like the Broom Creek Formation.

Flare Gas Quality

Bakken associated gas is described as “rich” gas, meaning that in addition to methane, it contains relatively high concentrations of higher-molecular-weight hydrocarbons, including ethane and NGLs. The specific composition of Bakken gas can vary by geography and over the life of a well.

Gas composition is an important factor when considering alternate uses. As a fuel, rich gas will burn hotter than methane because the NGL content results in a higher overall energy content per unit volume. Unprocessed associated gas is not directly interchangeable with natural gas-fired equipment. Additionally, and of direct relevance to this study, NGLs (which are gaseous at ambient conditions) can condense into liquids when compressed to pressures needed to inject them into geologic formations. Compression equipment must be carefully designed and operated to keep the mixture in a single gaseous phase and remove condensable hydrocarbons when necessary.

Flare Gas Quantity

The amount of gas being flared at a wellsite can vary widely depending on the age of the well, the rate of production, the properties of the oil at that location, and influences from other wells connected to the same gas-gathering infrastructure. A single well can produce as much as several million standard cubic feet of gas each day during the first several months of production. This rate tends to decline with time, and the rate of decline varies by well. A series of typical decline curves is illustrated in Figure 4. This figure also illustrates the increase in gas production from wells that have been completed more recently, suggesting that the challenges associated with gas capture will continue into the future as more wells are drilled and oil production increases.

If a well has no gas-gathering pipeline connection, 100% of this produced gas will be flared. Alternately, and more often the case, gas-gathering infrastructure is available to take most of the produced gas. However, high initial production, system maintenance, or high production from neighboring wells can lead to capacity constraints within this gathering network. In these situations, the amount of gas flared can vary from 0% to 100%. Analysis of production and flared gas data by the EERC (www.undeerc.org/flaring_solutions/Files-Reports.aspx) and the North Dakota Pipeline Authority (<https://ndpipelines.files.wordpress.com/2018/09/kringstad-ndpc-slides-sep-26-2018.pdf> – Slide 14) have illustrated the wide range of flared gas that may be present at a production location.

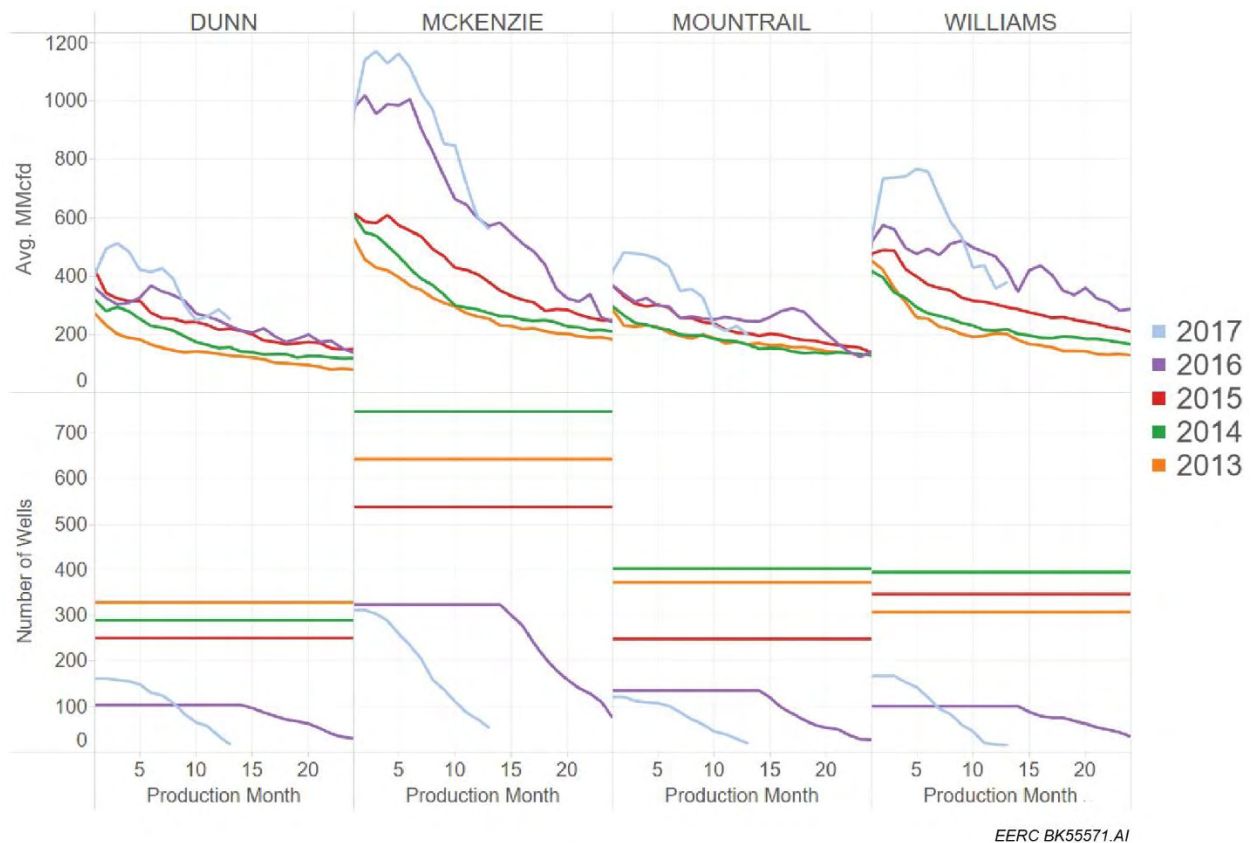

Figure 4. Average gas decline curves for Bakken and Three Forks wells based on county (image courtesy of the North Dakota Pipeline Authority: <https://ndpipelines.files.wordpress.com/2018/09/kringstad-ndpc-slides-sep-26-2018.pdf>).

Flare Gas Transience

Flaring, especially from wells connected to gas-gathering pipelines, is transient. This transience is largely due to the dynamic nature of gas-gathering system operation. The capacity of a gas-gathering system at any wellsite connection is impacted by the gas production rate and operating pressures of wells connected to the same gathering system. A large multiwell pad can overwhelm gathering pipeline capacity, causing gas from nearby wells to flare, when previously 100% of their production had been captured. This problem will likely continue into the future as GORs increase and as more wells are drilled and completed within a drill-spacing unit (DSU) and neighboring DSUs. An illustration of the transient nature of flaring is provided in Figure 5. The duration of flaring from any production location can vary from as short as a day to as long as 2 years, depending on the variety of factors discussed previously.

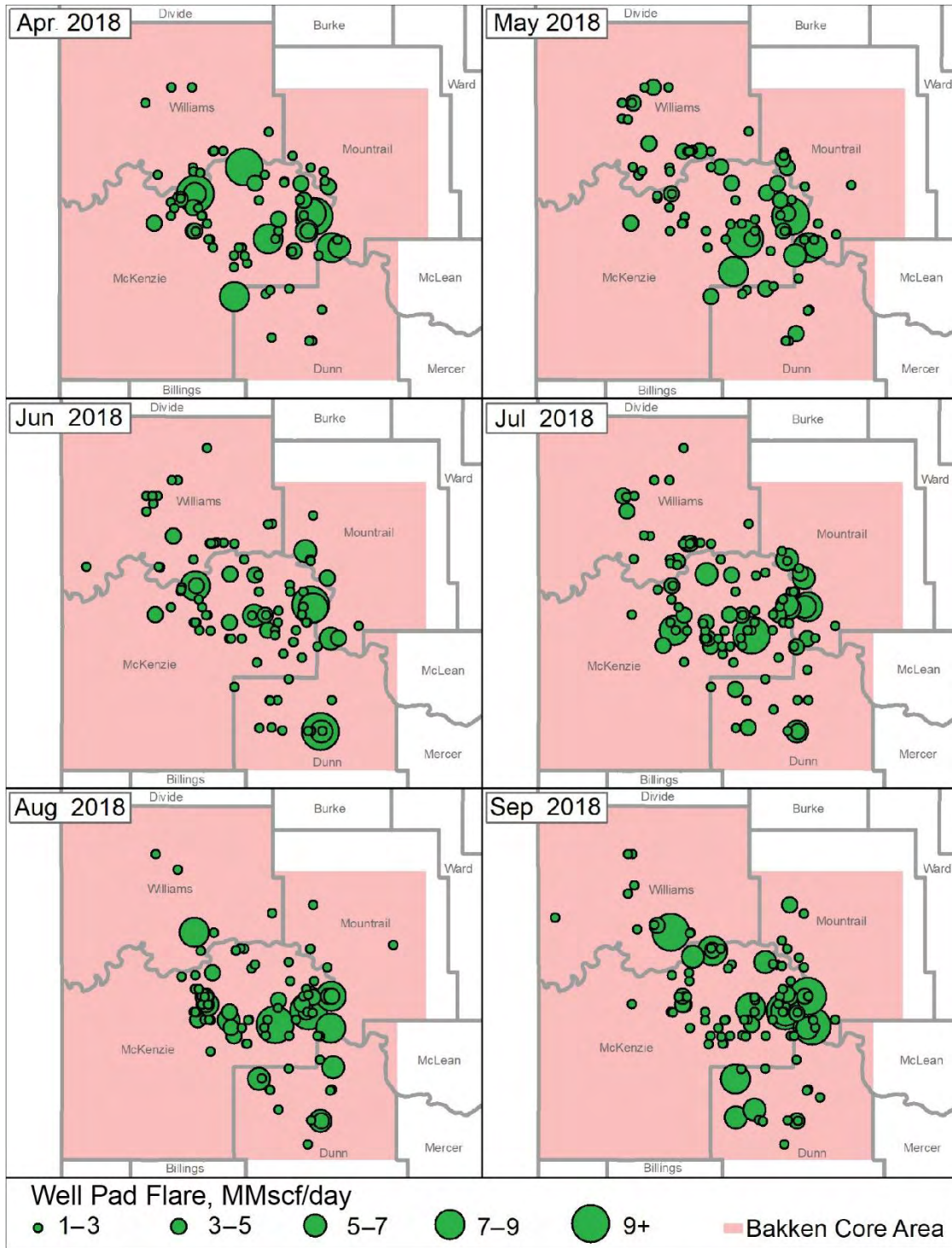

Figure 5. Illustration of the transient nature of flaring (note: only flares larger than 1 MMscf/day are plotted here).

SUBSURFACE GAS INJECTION

Given the dynamic nature of gas gathering, wide variability of flared volumes, and transient nature of flaring with respect to location, it is challenging to select a single flaring scenario that is representative of the various flaring cases in the Bakken currently or those that may exist in the near future. Gas injection into a geologic formation inherently benefits from larger scale with respect to the volume of gas handled, injected, and stored. Commercial gas storage has been practiced at very large scale for over a century, typically to balance the relatively steady production of natural gas in North America with the relatively seasonal demand associated with heating.

Typical large-volume natural gas storage sites include (partially) depleted oil/gas reservoirs, aquifers, and salt formations (beds, plumes, caverns, etc.), with depleted reservoirs generally being the better candidate (Katz and Tek, 1981). In these large-scale environments, geologic structure is used to create a gas–water cushion zone surrounding the gas bubble. The gas bubble, often referred to as working gas, is the gas that is added to or withdrawn to help meet current demands. The cushion/base gas is generally unrecoverable and can account for over half of the injected gas and 70% of the initial facility cost (Berger and Arnoult, 1989).

The key difference between the proposed temporary subsurface storage of Bakken natural gas and commercial geologic gas storage is the scale of operations. The scale of gas likely to be injected at wellsites targeting flare gas mitigation is relatively small compared to commercially operating gas storage facilities. Tables 1–3 were compiled with data from the Energy Information Administration (EIA) (2018) to summarize the general characteristics and operational parameters of various types of gas storage reservoirs at the field level.

As shown in the data, storage in salt domes on average requires the least amount of base gas, has the largest working gas volumes, and can output stored gas at higher rates. While aquifers have the largest total capacity of the storage reservoirs, this is due to the large volume of base gas required to maintain control over the working gas bubble and deliverability. While salt domes are prime targets for gas storage according to these numbers, depleted petroleum reservoirs are far more widespread and often have some degree of infrastructure already in place to manage pressure and gas bubbles. Aquifers and depleted petroleum fields have similar deliverability rates, which are limited by the need to maintain pressure control in the reservoirs.

Table 1. Summary of Total Capacity and Maximum Daily Gas Output of Commercial Gas Storage Sites Within Aquifers, Depleted Oil and Gas Fields, and Salt Domes (Energy Information Administration, 2018)

U.S. Natural Gas Storage Summary				
	Aquifers	Depleted Oil and Gas Fields	Salt Domes	Total
Total Capacity, Tcf	1.3	7.1	0.7	9.1
Maximum Daily Output, Bcf	9.2	73.7	36.0	118.8
Number of Storage Reservoirs	44	306	38	388

Data do not include facilities marked as inactive.

Table 2. Summary of Storage Parameters (on a volumetric basis) by Storage Reservoir Type for Commercial Gas Storage Sites Within the United States (Energy Information Administration, 2018)

U.S. Natural Gas Storage Averages			
	Aquifers	Depleted Oil and Gas Fields	Salt Domes
Base Gas, Bcf	21.2	10.4	5.2
Working Gas, Bcf	9.3	12.7	13.2
Total Capacity, Bcf	30.5	23.2	18.6
Max Daily Output, Bcf	0.21	0.24	0.95

Data do not include facilities marked as inactive.

Table 3. Summary of Storage Parameters (by percentage) and Storage Reservoir Type for Commercial Gas Storage Sites Within the United States (Energy Information Administration, 2018)

U.S. Natural Gas Storage Comparisons by Percentages									
	Aquifers			Depleted Oil and Gas Fields			Salt Domes		
	Ave	Min.	Max.	Ave	Min.	Max.	Ave	Min.	Max.
	% Base Gas of Total Capacity	66.9	18.0	91.3	47.6	6.4	96.1	32.0	14.4
% Working Gas of Total Capacity	33.0	8.7	82.0	51.5	3.9	91.5	66.5	35.1	86.3
% Max. Output of Working Gas	3.1	0.5	11.7	2.9	0.0	22.9	8.8	3.0	36.4

Data do not include facilities marked as inactive.

Another key difference between commercial-scale gas operations and the concept evaluated by the EERC is the reuse of the storage targets in commercial operations. By using the same injection target, less gas is needed to establish the gas cushion for subsequent storage. If gas storage projects are implemented in North Dakota to help achieve gas capture requirements, consideration should be given to reusing the same storage locations, either in subsequent cycles as more wells are brought online within a DSU or if they are in close enough proximity to other DSUs with insufficient gas capture infrastructure. This practice may increase the gas recovery factors for subsequent storage operations, depending on the scale and duration of injection and recovery.

Figure 6 is a map that depicts the distribution of U.S. natural gas storage reservoirs by type (Energy Information Administration, 2017). As illustrated, many commercial gas storage facilities are larger than 50 billion cubic feet (Bcf), a volume ten times larger than a typical wellsite could supply in a year.

For the purposes of this study the EERC assumed two gas injection scenarios for subsequent analysis of technical, economic, and regulatory implications: 10 and 30 MMscf/day. The first scenario assumes associated gas would be captured at the wellsite from a DSU, prior to entering the gas-gathering pipeline, and compressed into a gas injection well on the production location.

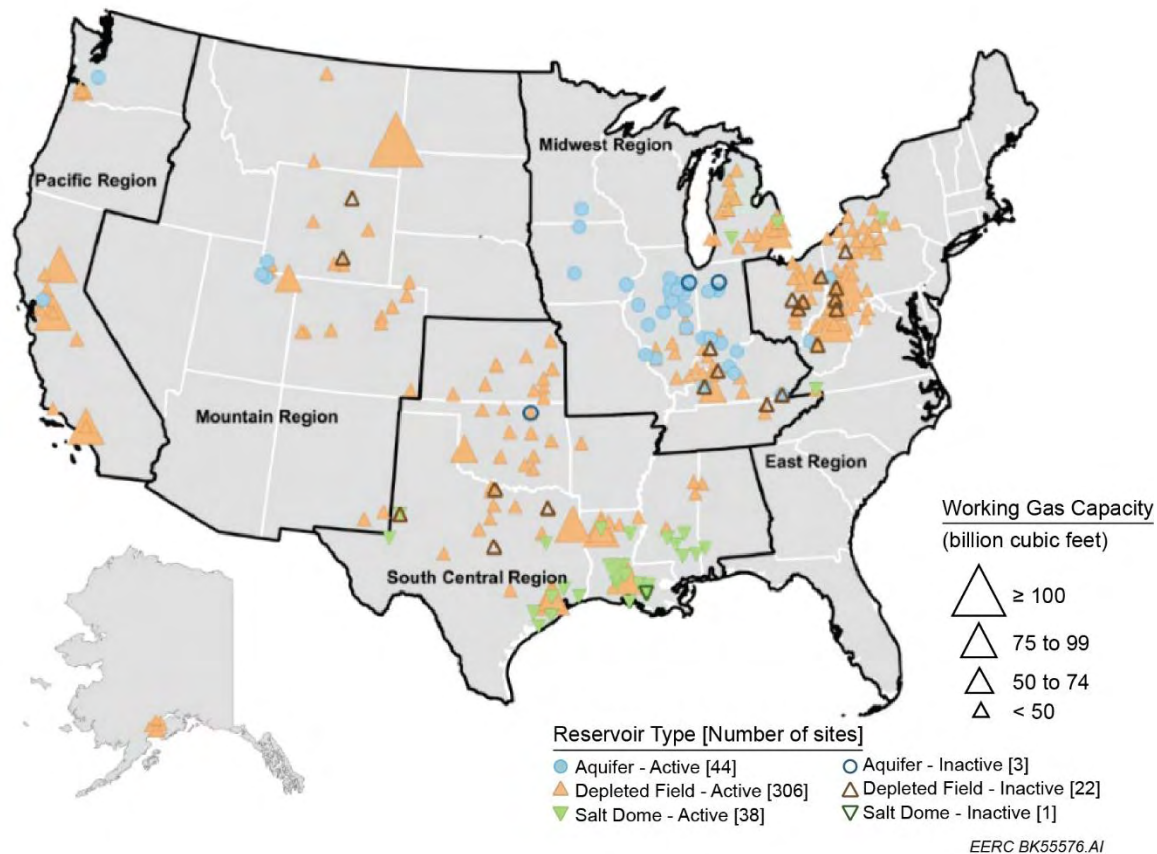

Figure 6. Distribution of U.S. natural gas storage reservoirs by type (Energy Information Administration, 2017).

Some DSUs can have multiple well pads; thus this assessment assumes that either a single multiwell pad exists on the entire DSU or that the gas volumes from multiple well pads on a single DSU would be aggregated. A large, multiwell pad on a single DSU early in the life of the DSU may be able to supply up to 10 MMscf/day for compression into a geologic formation. The vast majority of flares are significantly smaller than this; however, because of the high cost of implementing a gas injection project, smaller injection volumes were not considered. A second scenario of 30 MMscf/day was also considered, recognizing that, in some instances, larger gas volumes may be available downstream of a DSU at an intermediate gathering location. Recognizing the majority of flaring in North Dakota is occurring at locations that have gas sales but some level of capacity constraint, the EERC assumed a larger volume of gas may be available from the gathering network which, if removed from the gathering system, may increase capacity upstream. The larger injection scenario provides some economy-of-scale advantages but results in increased accounting challenges due to the contractual obligations of commingled gas within the gas-gathering system.

SIMULATION OF PRODUCED GAS INJECTION INTO THE BROOM CREEK

To evaluate the feasibility of produced gas injection and recovery into a subsurface saline geologic target, a reservoir simulation model for a portion of the Broom Creek Formation was developed. The reservoir model was constructed by coupling a geologic model developed using Schlumberger's Petrel E&P software platform (Schlumberger, 2016) with numerical simulation software developed by Computer Modelling Group's (CMG's) GEM Software (Computer Modelling Group, 2018). Once developed, the reservoir model was used to evaluate a variety of different gas injection and recovery scenarios, which are discussed further in subsequent sections of this report.

The Broom Creek Formation is a Pennsylvanian/Permian-age saline aquifer comprising primarily sandstone and carbonate (dolostone) and occurs at an average depth of 7400 feet in the core Bakken production area. The Broom Creek was selected as a target for simulation of produced gas injection and storage because of the existence of a recently developed reservoir model by the EERC that was designed to evaluate CO₂ injection into the subsurface. While the Broom Creek is a specific injection target, the thought was that the results of the simulation effort would provide insight regarding the feasibility of produced gas injectivity, subsurface gas migration, and gas recovery into similar geologic targets within the Williston Basin.

The model represented a 500-mi² (25-mi × 20-mi) area in Dunn and McKenzie Counties, centered on Little Knife Field (Figure 7). The simulation model was designed with open-boundary conditions allowing lateral water flux and pressure dispersion through simulated-boundary aquifers. Because the Broom Creek Formation contains no hydrocarbons, initial oil and hydrocarbon gas saturations were set at 0% (initial water saturation = 100%). Initial brine salinity was set at 100,000 mg/L total dissolved solids (TDS). The relative permeability assumed in the simulation was derived from literature that discusses gas flow in high-permeability saline sandstone formations (Bennion and Bachu, 2005). Different sets of relative permeability curves generated with correlation for water-wet, well-consolidated sandstones were evaluated and the impact on final gas recovery factor rate was investigated.

Injection and production well constraints were specified during initiation of the simulation model. The injected gas composition settings were that of typical Bakken produced gas composition (Table 4). Maximum injection pressure constraints were specified to limit simulation of scenarios that may result in fracture initiation in the injection zone and/or sealing formations.

Two injection well locations were included in the model (Figure 8). Well 1 was located on a structural high where injected gas would be trapped by subtle closure. Well 2 was located on the flank of a structural high. Structure was thought to be an important variable in simulation investigations, as gas tends to accumulate at the top of permeable intervals because of the effects of gravity segregation (buoyancy). Wellbore models were implemented to calculate injection wellhead pressure (WHP) response to injection rate, which is a common constraint for injection well permitting. Both wells were perforated in all of the sandstone intervals penetrated by the wellbore. No perforations were set in low-permeability rock.

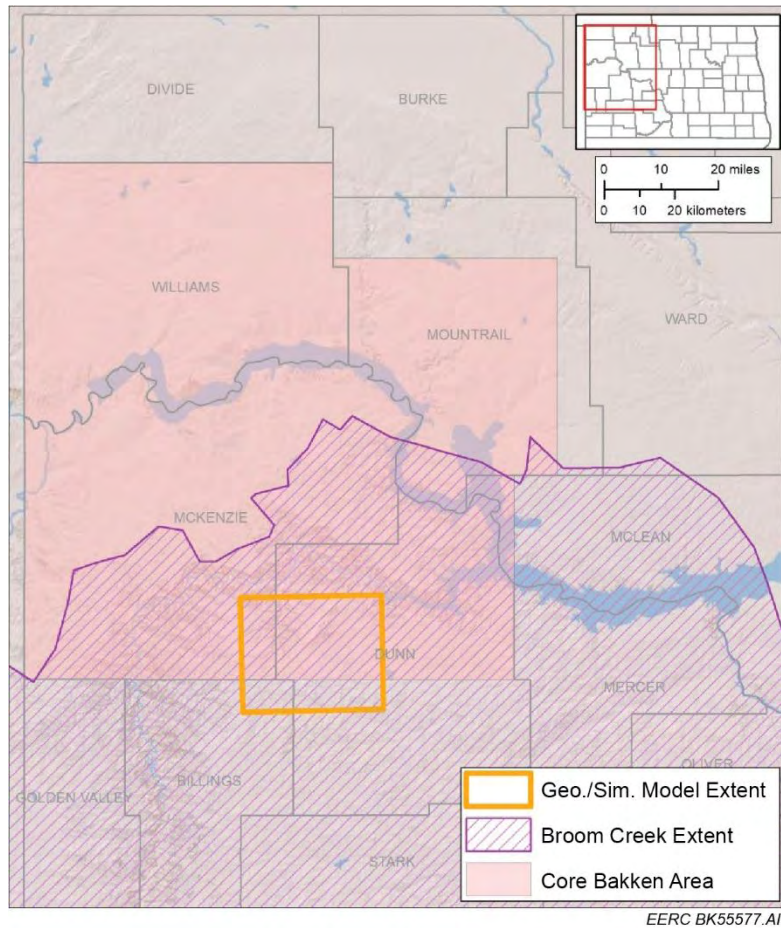

Figure 7. Map showing the location of the geologic and simulation model.

Table 4. Produced Gas Composition from a Typical Bakken Well

Gas Component	mol%
Methane	58.7
Ethane	21.6
Propane	12.1
Butane	4.0
Nitrogen	2.8
Carbon Dioxide	0.8
Hydrogen Sulfide	0.005

A variety of simulation scenarios were evaluated with the reservoir model. The full details of the reservoir simulation effort are included in Appendix A. Figure A-8 within the appendix summarizes each of the simulated cases along with the predicted gas recovery factors after 1, 2, and 5 years of production.

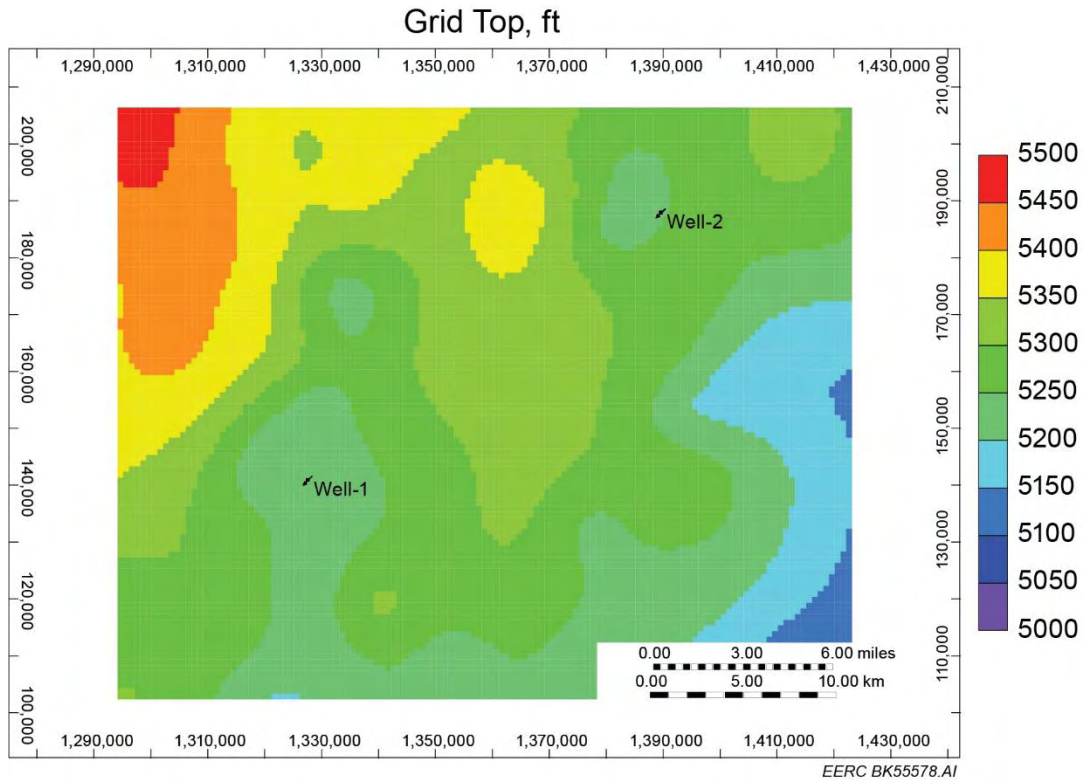

Figure 8. Map view of the simulation model showing the injection well locations and depth of the Broom Creek Formation top. North is toward the top of the image.

An overview of the different variables that were evaluated through the various simulation cases includes the following:

- Gas injection rates of 10 and 30 MMscf/day
- Gas injection periods of 6 months and 2 years
- Immediate gas recovery as well as recovery initiation after 1, 3, and 5 years
- Gas production rates constrained to 1, 2, and 10 MMscf/day
- Water production constrained to 10,000 bbl/day
- Cyclic gas injection and recovery with 4-year cycles

All of the simulation cases assumed that the gas would be produced without artificial lift, meaning that the gas and water would be produced by the hydraulic pressure of the reservoir (represented in the reservoir model by bottomhole pressure [BHP]). An initial case was run that had no constraints on producing BHP or water and gas production rates. The simulation resulted in periodic gas and water production as a result of BHP decreasing below the pressure needed to push the gas and water to the surface. The simulation case also resulted in low gas recovery factors (16%–27%) and very large water production rates (exceeding 12,000 bbl/day). Based on that initial case, it was decided that all of the subsequent cases would constrain BHP to no less than 3500 psi and water production to no more than 10,000 bbl/day.

As previously mentioned, the details of each simulation case are described in Appendix A. After running and evaluating several reservoir simulation cases, the results suggested that, if not constrained, early gas production rates could reach as high as 85 MMscf/day when the injection rate is at 10 MMscf/day. Gas production from the Broom Creek Formation at this high rate would likely exceed infrastructure capacity available at an individual well pad or DSU. Recognizing gas-gathering capacity would be the constraining factor influencing production rates, a series of simulation scenarios were evaluated over a production range of 1 to 10 MMscf/day. These cases are likely the most representative of the operational conditions to be encountered in the field and thus are described as follows.

The key parameters evaluated in these cases along with the resulting gas recovery factors are shown in Table 5. The cases assumed a 2-year gas injection period. While cases were evaluated with a 6-month injection time period, there were concerns that this time frame may be insufficient to allow the necessary gas capture infrastructure to catch up to demand.

Table 5. Simulation Scenarios for Cases Constraining Gas Production Rate

Injection Rate, MMscf/day	Gas Withdrawal after Injection	Gas Production Constraint, MMscf/day	Gas Recovery Factor after 1 year of Production (Well 1; Well 2)	Gas Recovery Factor after 2 years of Production (Well 1; Well 2)	Gas Recovery Factor after 5 years of Production (Well 1; Well 2)
10	Immediate	1	5%; 5%	10%; 10%	25%; 25%
		2	10%; 10%	20%; 20%	47%; 47%
		10	43%; 43%	51%; 49%	58%; 57%

As shown in Table 5 and Figure 9, the simulation results predict that gas recovery factors after 5 years of production would be approximately 25%, 47%, and 58% if gas production were constrained to 1, 2, and 10 MMscf/day, respectively. Figure 10 suggests that constraining the gas production rate to 1 and 2 MMscf/day would result in a steady gas production rate and significantly reduced water production rates. If production was limited to 1 MMscf/day, the simulation results suggest that the water production rate would not exceed 200 bbl/day. Limiting production to 2 MMscf/day resulted in an estimated water production rate of less than 500 bbl/day for the first 3.5 years, followed by an increase approaching 2700 bbl/day nearing the fifth year.

Although the case where gas production is constrained to 10 MMscf/day resulted in a much higher water production rate, it also had the highest recovery factor. In addition, the majority (88%) of the recoverable gas (based on the volume recovered after 5 years of production) was produced after 2 years of recovery, suggesting that there could be options to optimize the economics of the operation by limiting the duration of gas recovery. Because water production increases as gas production decreases, limiting the gas recovery operation to the first few years or so would also decrease the volumes of produced water generated and associated costs for disposal.

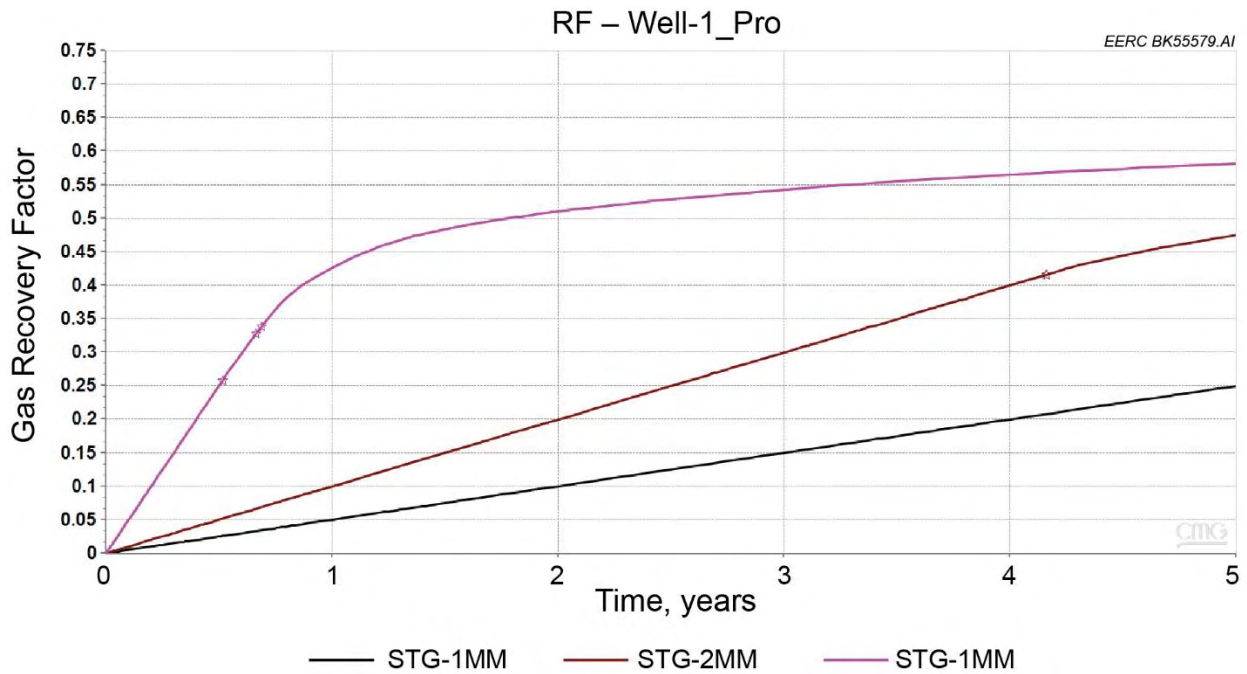

Figure 9. Gas recovery factor for Cases 22–24.

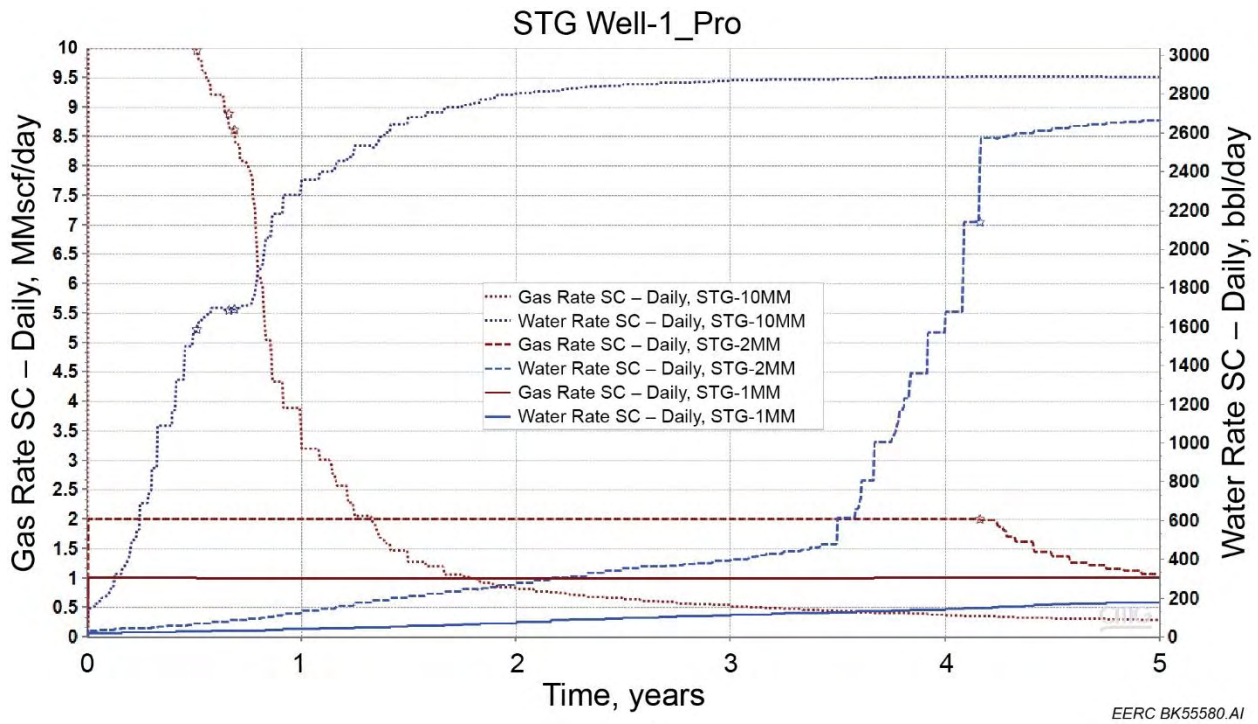

Figure 10. Water and gas production rates from Well 1 for Cases 22–24 (SC is standard conditions).

Figure 11 illustrates the cross-sectional and aerial extent of the simulated gas plume for Well 1 after 2 years of injection at a rate of 10 MMscf/day. The aerial plume extent is a summation derived from each of the vertical layers contained within the reservoir model.

One final injection scenario was evaluated to simulate a case where a DSU has been partially developed (i.e., five wells developed out of 20 planned); however, the drilling and completion of new wells on the DSU are delayed until sufficient capacity exists in the gas-gathering infrastructure at the site. Rather than wait for pipeline capacity to become available, an operator could decide to implement a subsurface gas storage operation at the site so that the excess (uncaptured) gas from new wells could be injected rather than flared. The scenario assumed that five new wells would come online at a time for a total of three cycles, with 4 years in between each batch of well development. Once each batch of five wells comes online, the produced gas that cannot be conveyed in the existing gas capture infrastructure would be injected into the Broom Creek for 2 years at an assumed rate of 10 MMscf/day. After 2 years of injection, the gas would be recovered for a period of 2 years and conveyed off-site by the gas capture infrastructure. The assumption is that with 4 years between each development cycle, the gas production from the existing wells on-site should decline enough to free up significant additional capacity in the pipeline infrastructure. In a real-world case, the actual rates of gas injection and recovery would likely be variable over the 2-year injection and recovery period based on how much gas is produced from the new wells, the existing wells, and the available pipeline capacity.

The results of this scenario are shown in Figure 12. With each subsequent gas recovery period, the gas recovery rate remains at 10MMscf/day for a longer period of time, the water recovery rate decreases, and the overall gas recovery factor increases. This allows for increased gas recovery during each subsequent cycle. In this scenario, the gas recovery factors were estimated at approximately 50% after the first 2-year recovery period, 57% after the second period, and 63% after the third period. As mentioned in the literature describing commercial-scale gas storage projects, this is likely because after the initial gas injection operation, less gas is needed to establish a gas cushion in the reservoir for each subsequent injection operation. Rates of water production decreased with each subsequent cycle, with a production rate of approximately 2750 bbl/day after the first 2-year recovery period and decreasing to a high of 2000 bbl/day at the end of the third 2-year recovery period.

One of the key benefits of a cyclic approach to gas injection and recovery is that reuse of the same location for gas injection allows the cost for development of the surface facilities (compression, gas, and saltwater disposal [SWD] wells) to be spread out over three gas injection and recovery operations (as opposed to just one). In addition, this approach could significantly shorten the period of time needed to fully develop all of the planned wells on a pad by providing a mechanism to store excess gas. This gas storage reservoir also allows the producer to better handle fluctuations in wellsite gas production and/or pipeline capacity upsets.

Summary of Simulation Results

To bracket the various operational conditions that might be encountered in the field, several simulation scenarios were evaluated, including two different injection rates (10 and

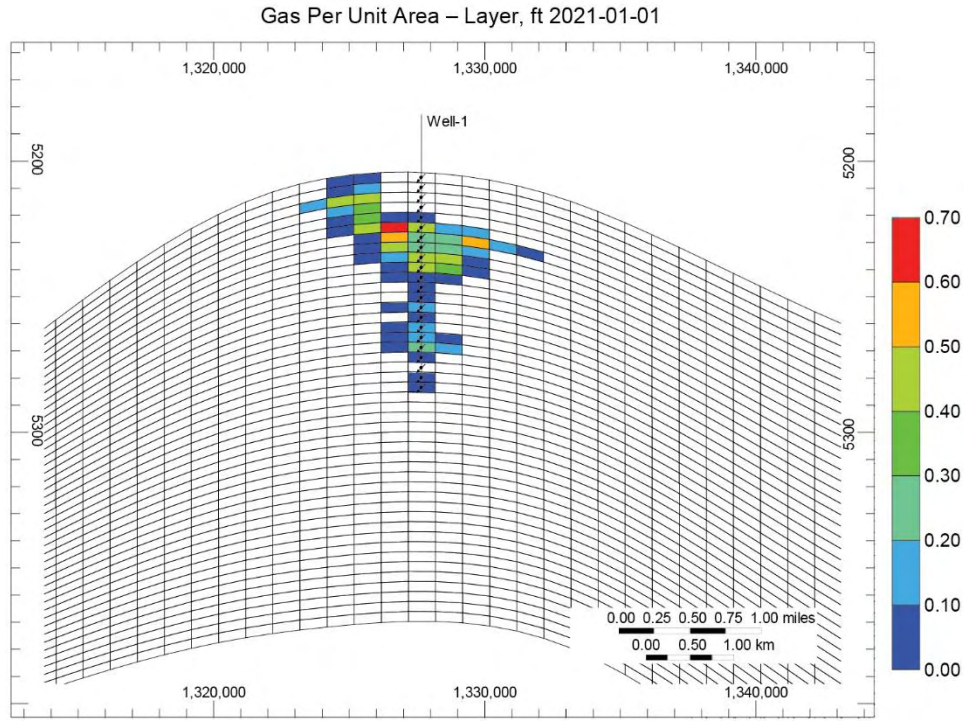

(a)

EERC BK55581.AI

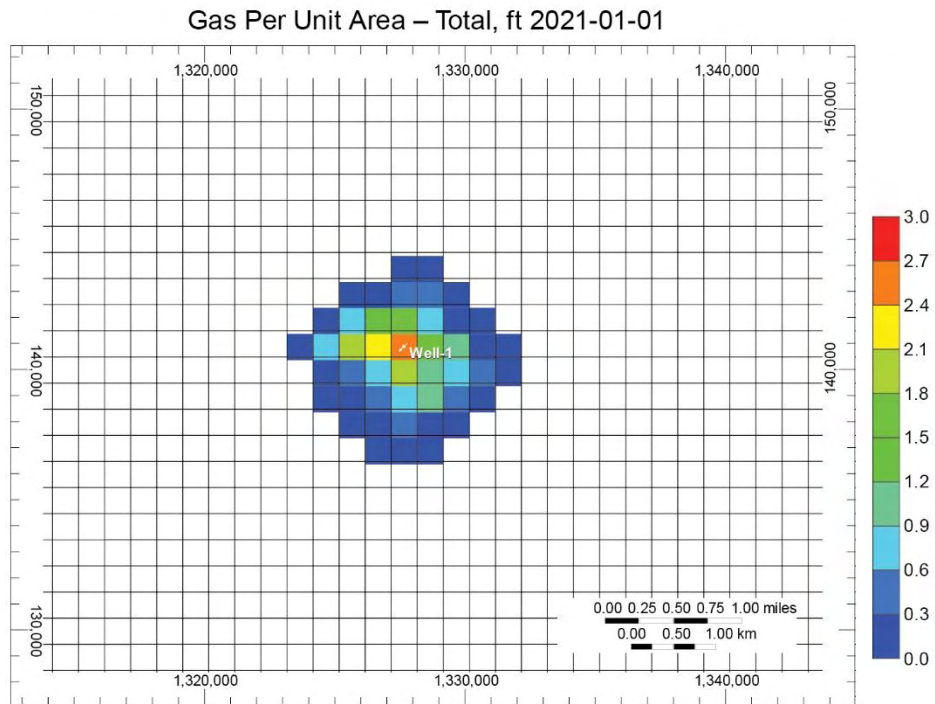

(b)

EERC BK55582.AI

Figure 11. Cross-sectional view (a) and aerial view (b) of one simulated gas plume after 2 years of injection at 10 MMscf/day (note that the aerial extent is a summation derived from each of the vertical layers in the reservoir model). The vertical exaggeration in image “a” is 75×.

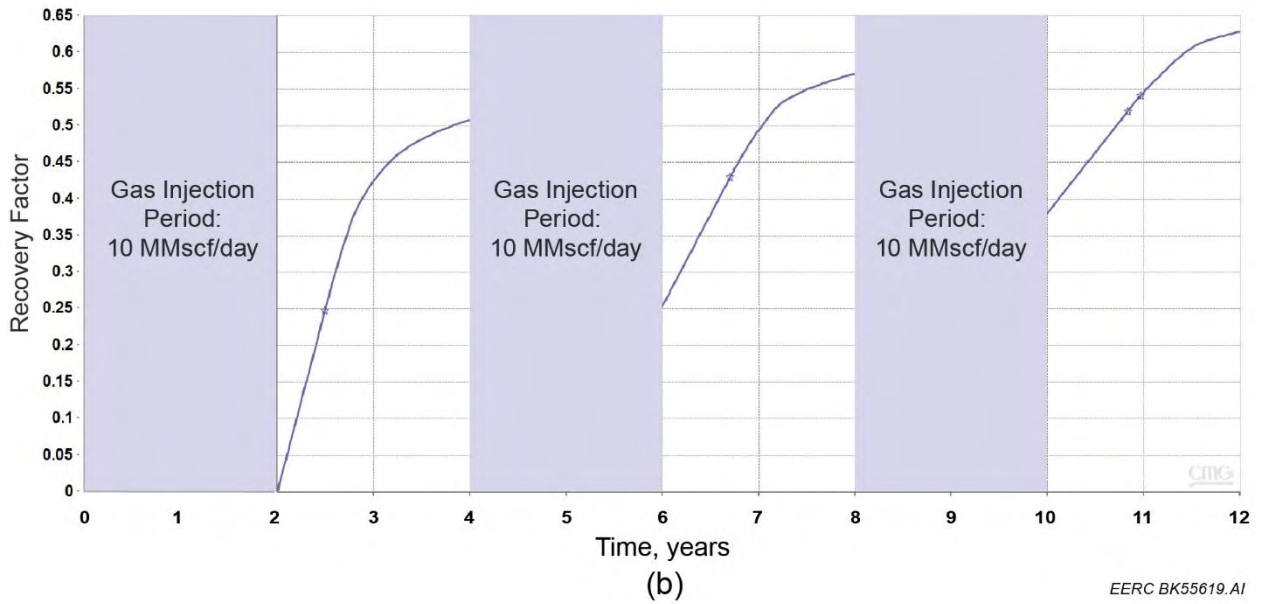
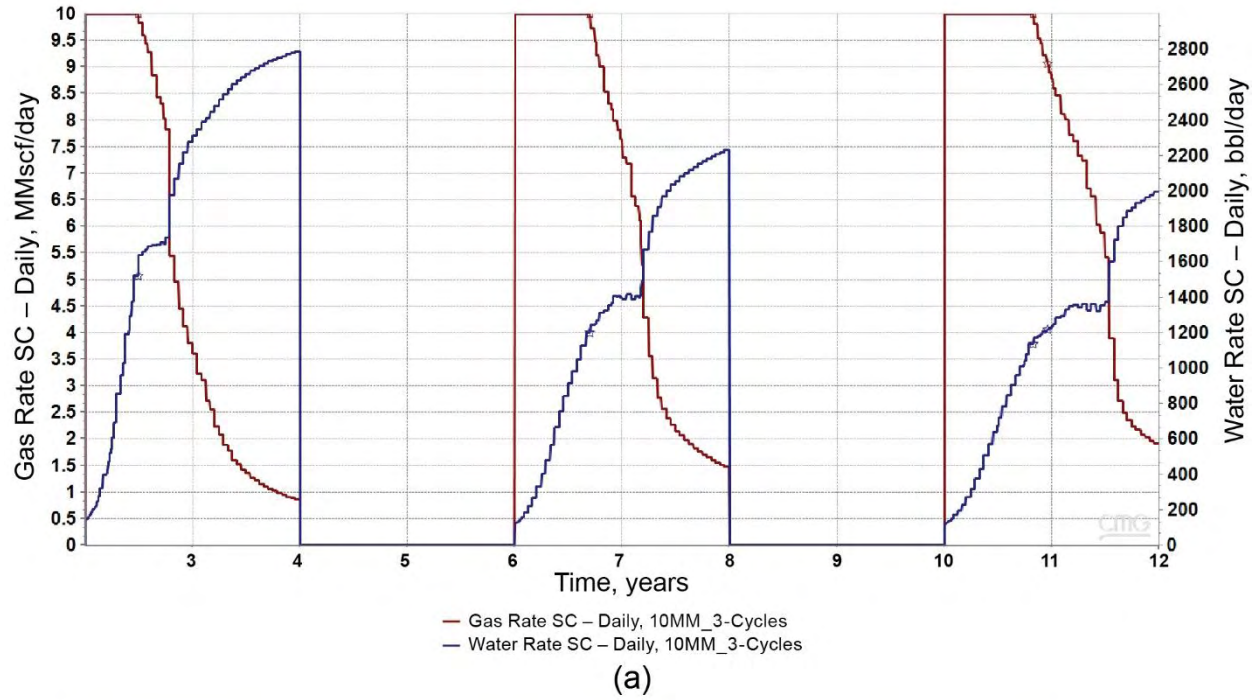

Figure 12. Gas and water production rates following 2 years of gas injection (a) and gas recovery factors (b) for a cyclic gas injection and recovery scenario.

30 MMscf/day), two different injection periods (6 months and 2 years), and multiple recovery periods (immediate recovery and recovery after 1, 3, and 5 years). In addition, because the simulation results highlighted the potential issues that could occur with respect to both gas and water production rates, additional simulation cases were evaluated. These cases included the effects of various gas production constraints (1, 2, and 10 MMscf/day) and limiting water production to no more than 10,000 bbl/day. Finally, a scenario evaluating the use of a storage site for cyclic gas injection and recovery was evaluated.

A table summarizing each of the simulation cases and the predicted recovery factor after 1, 2, and 5 years of production is included in Appendix A (Table A-9). Recovery factors generated from the various simulation cases (excluding the initial simulation case with no lower BHP limit) ranged from a low of 25% to a high of 74% after 5 years of gas recovery from Well 1 and a low of 25% and a high of 64% from Well 2. In each batch of simulation cases, the highest gas recovery rates were seen with gas injection for 6 months or 2 years, followed by immediate recovery. As would be expected, the lowest recovery factors were seen in the cases where gas production rates were limited to 1 and 2 MMscf/day. If these two cases are excluded, then the lowest gas recovery rates after 5 years of production were 31% and 29% for Wells 1 and 2, respectively. The simulation results suggested that when not constraining the gas production rate at a lower level (1 or 2 MMscf/day), on average, approximately 90% of the recoverable gas (based on a 5-year recovery period) is retrieved after 24 months of production.

The cyclic gas injection scenario suggested that reuse of the same injection target would help improve gas recovery and reduce water production after each subsequent cycle. If three cycles of gas injection occurred at a rate of 10 MMscf/day for 2 years, followed by 2 years of gas recovery, the gas recovery factors were estimated at approximately 50% after the first 2-year recovery period, 57% after the second period and 63% after the third period. Rates of water production decreased with each subsequent cycle, with a production rate of approximately 2750 bbl/day after the first 2-year recovery period, and decreasing to a high of 2000 bbl/day at the end of the third 2-year recovery period. If this approach were applied preemptively, it could significantly shorten the period of time needed to fully develop the planned wells on DSUs that are constrained by limited gas capture infrastructure by providing a mechanism to store excess gas. Having the option for subsurface gas storage on-site also provides the producer with the agility to better handle fluctuations in wellsite gas production and/or pipeline capacity upsets without significant interruptions in oil production.

Water production rates typically increase dramatically within the first 6 to 12 months of production; thus from an operational and economic standpoint, the simulation results suggest that shorter gas recovery periods may be more realistic, otherwise water production and associated handling costs increase dramatically with little additional gas recovery. The case involving cyclic gas injection and recovery suggested that water production rates decrease significantly after each subsequent cycle with increasing gas recovery factors.

In almost all cases, significant differences in recovery were seen between Wells 1 and 2, with Well 1 exhibiting higher recovery factors than Well 2. As expected, this indicates that sites with geologic structure to help contain gas and fluid movement will likely result in higher gas

recovery factors. Site-specific characterization and reservoir simulation efforts would be needed to better define the gas injectivity and recovery performance for individual sites.

Constraining gas production to 1 to 2 MMscf/day significantly reduced water production, at the cost of longer gas recovery periods and lower gas recovery factors. A constrained gas production rate of 10 MMscf/day resulted in improved gas recovery but also higher water production rates. Ultimately, in any gas storage project, the site-specific conditions will need to be evaluated and the balance between gas recovery rates and volumes will need to be balanced with the available gas pipeline capacity and operational costs of the site, including water handling and disposal.

ASSOCIATED GAS INJECTION SURFACE FACILITY DESCRIPTION AND COST

Surface Facility System Description and Design

To enable an engineering estimate of cost for gas injection into a geologic formation, a high-level process design was developed for two systems: a gas compression system and a stored gas recovery system. The basis for scenario selection and equipment design was derived from knowledge about the dynamics and scale of flared gas in North Dakota, results from the multiple scenarios evaluated by reservoir simulation, and a number of assumptions about how a geologic gas storage project might be executed. The equipment design and costing conducted here represents a relatively small range of scenarios that could be achieved and is not exhaustive. Nonetheless, it provides an example of the level of effort and investment necessary to achieve flared gas storage in a geologic formation.

Following is a summary of the key assumptions used for this design:

1. Equipment design is based on stand-alone equipment packages requiring minimal support from existing infrastructure.
2. Flared gas volume and composition are variable. Values used in this analysis represent a snapshot in time/space and are not representative of flaring everywhere.
3. Dedicated gas and produced water injection wells will be installed near the gas reception points.
4. Assumed operating conditions for the gas injection system and the stored gas recovery system are summarized in Table 6.

Table 6. Summary of Operating Conditions for Gas Compression and Gas Recovery Systems

Scenario	Wellsite	Gas-Gathering Pipeline
Gas Compression System		
Gas Injection Rate, MMscf/day	10	30
Gas Quality	Rich gas	Rich gas
Feed Gas Conditions, °F/psig	110/60	60/60
Injection Pressure, psig	3,500	3,500
Injection Period, years	2	2
Gas Recovery System		
Gas Recovery Rate, MMscf/day	2	2–10
Produced Water Rate, bbl/day	500	500+
Wellhead Conditions, °F/psig	60/1500	60/1500
Recovery Period, years	2 to 5	2 to 5

Gas Compression System Description

Process Description

The compression system designs assume that rich gas is supplied to the compressor from a connection downstream of the product separator and before the meter (lease automatic custody transfer [LACT] unit) at the wellsite or from the gathering line in the DSU. Multiple gas-driven, four-stage compressors with interstage air coolers and a glycol dryer pressurize the gas for injection while simultaneously drying the gas and removing some of the heavier hydrocarbons (NGLs). Compressors and associated equipment and instrumentation are factory-fabricated and assembled, skid-mounted units. Each train consists of a compressor/cooling skid and a glycol dryer skid capable of compressing 5 MMscf/day of rich gas and, if desired, a pressurized NGL storage tank able to store 80 bbl/day. The gas injection well is assumed to be very near the compressor to minimize cost of flow piping from the compressor to the well.

Cost

Compression capacity is supplied by multiple trains of 5-MMscf/day rich gas compressors – two trains for 10-MMscf/day compression and six trains for 30-MMscf/day compression. Costs are assumed to be simple multiples of a single-train cost. Trimeric Corporation and the EERC developed independent purchased-equipment cost estimates for the 5-MMscf/day train which, considering the inherent error of the methods, produced equivalent results. While both evaluations made extensive use of cost estimation software, Trimeric’s estimate also included vendor cost estimates; consequently, Trimeric’s purchased-equipment cost estimate is presented in Table 7. This table presents both purchased equipment costs for a single 5-MMscf/day gas compression system and the total fixed-capital investment for that system. The total purchased-equipment cost for the compression system includes only the cost of equipment, not installation or ancillary process controls or equipment. Standard factors (Peters and Timmerhaus, 1991) were applied to

Table 7. Gas Compression System Cost Estimate

5-MMscf/day Capacity	2016, US\$	2016, US\$
Compressor Skid	1,600,000	
Glycol Dryer Skid	95,000	
NGL Storage	200,000	
Total Purchased-Equipment Cost		1,895,000
Purchased-Equipment Factor		0.4
Total Surface Equipment Fixed-Capital Investment		4,700,000

the purchased-equipment cost estimate to generate an approximation of fixed-capital investment which accounts for all of the costs needed to install and operate a piece of purchased equipment. These standard factors consider costs for instrumentation, piping, and electrical equipment and their cost of installation; buildings and service facilities; engineering; site preparation and construction; and contingency. Table 8 provides a summary of total capital costs for gas compression and injection for each of the two injection rate scenarios.

Table 8. Gas Injection System Capital Cost Estimates

	10 MMscf/day Rich Gas	30 MMscf/day Rich Gas
Number of 5-MMscf/day Trains	2	6
Single Compression Grain Fixed-Capital, US\$ investment		4,700,000
Surface Equipment Cost, US\$	9,400,000	28,200,000
Gas Injection Well Cost, US\$	2,000,000	2,000,000
Total Gas Injection System Capital Cost, US\$	11,400,000	30,200,000

Stored Gas Recovery System

Process Description

The gas recovery and water injection system is comprised of a two-phase separator and scrubber, a saltwater tank, and an injection pump. Similar to the compression system, the gas recovery systems (separator vessels and associated equipment and instrumentation) are factory-fabricated and assembled, skid-mounted units, as is the pump. Both skids are sized to process the constrained flow from the well. The separator vessel skid is assumed to be located near the gas injection/recovery well, and the produced water tank and injection skid are to be located near the water injection well. Economic analysis assumed a minimum distance between wells.

Cost

The EERC applied Aspen Technology's Aspen Process Economic Analyzer 10 to develop a purchased-equipment cost estimate for a nominal 1-MMscf/day gas recovery and water injection system. The purchased equipment was scaled using standard factors (0.34 for the pump and 0.57

for the tank and separation vessels) to estimate the purchased-equipment cost for 2- and 10-MMscf/day units. Total equipment fixed-capital investment estimates were derived using a 0.38 factor applied to the purchased-equipment cost estimate. As stated earlier, the purchased equipment factor accounts for the costs required to install a piece of purchased equipment and make it operational. A summary of these costs is provided in Table 9.

Table 9. Gas Recovery and Water Injection System Cost Estimates, US\$

	1 MMscf/day Gas Production	2 MMscf/day Gas Production	10 MMscf/day Gas Production
Pump	\$600,900	\$760,600	\$1,314,600
Tank	\$45,900	\$68,100	\$170,500
Separation Vessels	\$32,400	\$48,100	\$120,400
Total Purchased-Equipment	\$679,200	\$876,800	\$1,605,500
Purchased-Equipment Factor	0.38	0.38	0.38
Total Surface Equipment Fixed-Capital Investment	\$1,800,000	\$2,300,000	\$4,200,000
Water Injection Well Cost	\$2,000,000	\$2,000,000	\$2,000,000
Total Gas Recovery and Water Injection System Capital Cost	\$3,800,000	\$4,300,000	\$6,200,000

Overall Capital Equipment Cost Summary

A summary of total equipment cost is provided in Table 10 for the two injection scenarios evaluated. The estimated capital cost for an injection capacity of 10 MMscf/day is \$15.7 million and \$34.5 million for a capacity of 30 MMscf/day. This equates to a cost of \$2.15/Mcf based on the cumulative volume of injected gas, assuming an injection rate of 10 MMscf/day for 2 years. The estimated cost would be \$1.57/Mcf based on the cumulative volume of gas injected over 2 years at a rate of 30 MMscf/day. These costs include an estimate for a gas injection well (also used for gas recovery following injection) and water injection well and fixed-capital investment costs for the gas compression system and stored gas recovery system. These values represent a $\pm 50\%$ estimate and can vary significantly based on site-specific conditions. Nonetheless, these data provide a framework from which to assess the implementation of a geologic storage project.

Table 10. Combined Capital Equipment Costs for Geologic Storage of Associated Gas, US\$

	10-MMscf/day Scenario	30-MMscf/day Scenario
Gas Compression/Injection System	11,400,000	30,200,00
Stored Gas Recovery System, 2-MMscf/day basis	4,300,000	4,300,000
Total	15,700,000	34,500,000

The capital costs summarized above are based on the average depth and pressure of the Broom Creek Formation; however, there are many other potential geologic injection targets in western North Dakota (described later in this report), all of which are deeper than the Broom Creek. The increased depth of these storage targets will increase the capital (and operational) costs for compression as well as the costs to drill gas injection and SWD wells.

Additional Cost Considerations for Geologic Gas Storage

In addition to the capital costs presented above, numerous other costs would be necessary to implement a large-scale gas storage project. Many of these costs are difficult to estimate because of site-specific conditions, an individual company's unique business/financial model, or lack of regulatory certainty. It is beyond the scope of this study to perform a detailed economic analysis of geologic gas storage; nonetheless, it is useful to identify factors that could be considered in such an analysis, including the following:

- Labor to operate gas injection and gas recovery equipment would represent an addition to existing production costs. Gas compression tends to be a relatively high maintenance operation when compared to typical oil production systems. Using standard engineering factors for operating costs, it is reasonable to assume \$1 million/yr ($\pm 50\%$).
- Gas compression is an energy-intensive process requiring either electricity or natural gas to power the equipment. Operational costs associated with these utilities can be as high as \$1 million/yr for a 10-MMscf/day injection, depending on negotiated electrical rates or accounting for the value of gas.
- Royalty payments and taxes on stored gas. The basis for royalty and tax payments is uncertain for gas that is produced, stored in the subsurface, and then recovered later for delivery to market. Because not all of the gas injected into the subsurface is recovered, the basis for payments can have a large impact on the value of those payments.
- Lease of pore space for stored gas. Cost would be based on a negotiation between the oil producer and the pore space owner. Additional regulatory clarity would be needed in this area before costs can be estimated.

Economic Benefit

In an effort to define the potential economic benefit of geologic gas storage, a rudimentary analysis was conducted on a basinwide level. Assumptions for this analysis obtained from the North Dakota Department of Mineral Resources (DMR) Director's Cut (www.dmr.nd.gov/oilgas/directorscut/directorscut-2018-11-16.pdf) include the following:

- Current gas capture target is 88%.
- September 2018 gas capture was 82% (most recent statistics).
- September 2018 crude oil price was 59.05/bbl oil.

Based on these values, capture of an additional 150 MMscf/day would result in statewide compliance with gas capture targets. At an average GOR of 1.9 Mcf gas/bbl oil, this volume of gas

capture could contribute to an additional 80,000 bbl of oil production, assuming that oil curtailment is occurring as a result of falling below the capture target. At oil prices of \$59/bbl, the economic value associated with that volume of oil is \$4.7 million/day.

The actual amount of oil curtailment occurring in North Dakota is unknown. One estimate of voluntary curtailment made by DMR in September 2018 based on input from the top ten oil producers in the state was 50,000 bbl/day (Bismarck Tribune, 2018). The value of this oil at \$59/bbl equates to almost \$3 million/day. At that time, the statewide gas capture target was at 85%, and it has since increased to 88%, which has likely resulted in even larger volumes of voluntarily curtailed oil production.

An underlying premise of this study is that long-term, large-scale stranded gas is needed for geologic storage and that such stranded gas may exist at production locations that are 1) not connected to gas-gathering infrastructure or 2) experiencing significant capacity constraints. Under these conditions, producers are faced with the decision of deferring well completions and flowback or finding alternate uses for up to 100% of produced gas until gas-gathering capacity improves. For a producer that is failing to meet its gas capture targets, it is reasonable to assume that any new production would need to involve some form of alternate gas capture.

Estimating the benefits of gas capture on a localized scale, such as a DSU, is difficult because so few publicly available data exist regarding the DSU development plans of operators and how those plans are being impacted by a lack of gas capture infrastructure or pipeline capacity at individual sites. If we assume that operators preemptively plan for subsurface gas injection in order to bring new wells online and that nearly that entire volume of gas would require temporary storage, then a generalized estimate of the economic value of that oil production can be made. Based on extrapolation of data from Helms (2018), the average rate of gas production from a typical Bakken well in 2018 is approximately 2 MMscf/day in the first 2 years of production. Using the decline curve for a typical Bakken well, the cumulative gas produced (exceeding gas capture targets) after a period of 2 years would be about 1.3 Bcf, which is equivalent to approximately 690,000 bbl of cumulative oil production. The value of that oil after 2 years (assuming \$59/bbl) is \$41 million. If five wells producing at this rate were brought online at once, that would be equivalent to a gas production rate on the DSU of approximately 10 MMscf/day. The value of the associated oil production would be approximately \$200 million. This may be an overly optimistic assumption, as the dynamics of gas-gathering capacity could easily reduce the gas volume available for injection and the associated value (incremental oil produced). Gas capture is complex, and many options exist that can reduce the quantity of “stranded” gas available at a wellsite and the associated economic benefit from geologic storage. These options were not included in the above analysis and include exemption of 60-day initial production from gas capture requirements, gas capture carryover credits, compressed natural gas (CNG) and liquefied natural gas (LNG) credits, stranded gas designation, and force majeure exemptions. Considering the multitude of factors influencing gas capture determination and impact on oil production, a site-specific analysis is critical to evaluating the economic benefit for any particular scenario.

Other factors that will affect the economic benefit of gas storage include the recovery efficiency of the stored gas and the price of gas at the time of recovery. Also, as discussed in the next section of this report, there are several other formations in North Dakota that could serve as

subsurface injection targets, many of which could provide opportunities for enhanced oil recovery (EOR). The recovery of oil from an injection target would not only provide extra revenue from oil sales, but also the avoidance of potential payments to pore space owners for storage in non-hydrocarbon-bearing formations.

As an example of the potential economic benefits of oil recovery from a conventional oil formation using hydrocarbon gas, the Red Wing Field operation that was active from 1981 to 1997 can be examined. Based on information available in the literature (Pickard, 1994; North Dakota Industrial Commission, 2018a, b), the EOR approach entailed injecting slugs of liquefied propane alternating with periods of methane gas. The volumes of propane and methane injected into the field for a 6-year period that lasted from August 1981 to August 1987 were available in the literature along with the volumes of incremental oil generated. Over that period, a total of 23.5 MMgal (846.6 MMscf) of propane and 482.7 MMscf of methane were injected, a volume that is considerably less than the volume of gas considered in the scenarios evaluated through this effort. After 6 years of propane and methane injection, the estimated incremental oil recovery was 500,000 bbl. At an oil price of \$59/bbl, that equates to an additional \$29.5 million. At this 2.65-MMscf/bbl net utilization rate, with 7.3 Bcf of gas (equivalent to injecting 10 MMscf/day for 2 years), it would equate to 2.75 MMbbl of oil valued at \$162.5 million.

ALTERNATIVE TARGETS FOR PRODUCED GAS INJECTION

Although the reservoir simulation activities of this effort focused on the Broom Creek Formation as an example, there are many other injection targets in the Williston Basin, including other saline aquifers as well as conventional and unconventional oil and gas reservoirs. Ideally, storage formations should have adequate reservoir thickness and injectivity (a combination of porosity and permeability) to accommodate a target volume of gas for storage. Additionally, an overlying low-permeability cap rock lithology (shales, salts, or tight carbonates) is important for the containment of the injected gas within the reservoir formation.

Another important geologic aspect for increasing recovery of injected gas from storage reservoirs is the presence of geologic traps. Storage targets with structural and stratigraphic traps (Figure 13) provide the best potential scenarios for gas storage because the geologic structure helps contain the gas, thereby increasing ultimate recovery. Without a structural or stratigraphic trap, the injected gas is more likely to spread out laterally from the injection well, decreasing the ultimate recovery of the injected gas.

The Williston Basin is a simple sedimentary basin with limited structural features (Pollastro and others, 2012). Most structural trapping within the Williston Basin that could be used for gas storage would likely be associated with one of the major structures shown in Figure 14. These structures have influenced many of the formations in the Williston Basin, creating features that have trapped hydrocarbons, resulting in the formation of conventional oil fields. These structures have also created traps in formations where hydrocarbons are absent.

Structural Traps

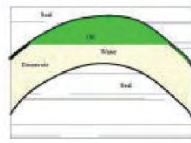

Anticline

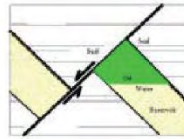

Fault

Stratigraphic Traps

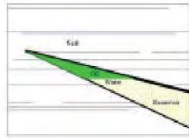

Pinchout

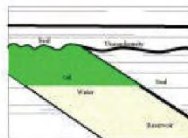

Unconformity

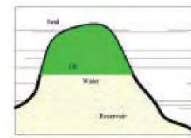

Reef

EERC BK55585.AI

Figure 13. Types of structural and stratigraphic geologic traps.

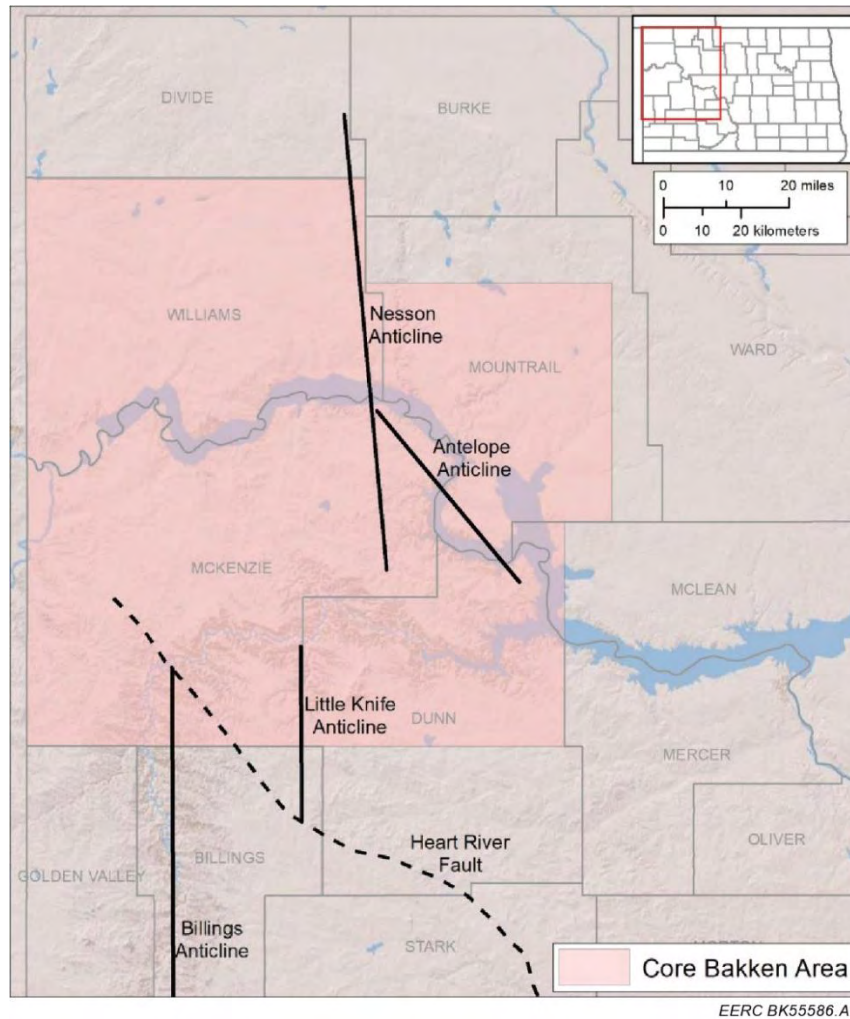

Figure 14. Major geologic structures within the Williston Basin of North Dakota.

An example of a structural development in the Williston Basin that has influenced multiple formations can be found in the Little Knife Field. Oil and gas production from the Little Knife Field originates from a north-plunging structural nose in the Mission Canyon Formation (Figure 15) (Wittstrom and Hagemeyer, 1978). This same structural feature is also evident in the overlying Broom Creek Formation (Figure 15), which could be used for produced gas storage. The Little Knife structure may allow for better ultimate gas recovery by containing the injected gas within the structural feature. However, it should be noted that areas that contain structural traps in the Williston Basin were likely targeted for oil and gas production in those formations that contain hydrocarbons. Thus, while the Broom Creek itself is not a hydrocarbon-bearing formation, in the area overlying the Little Knife oil field, it has been penetrated by multiple wellbores targeting the underlying Mission Canyon Formation. These wellbores, many of which were drilled in the 1950s and 1960s, could provide potential pathways for leakage of injected gas. Produced gas injection targets that are penetrated by multiple wellbores will likely require a more rigorous monitoring program by DMR to ensure that no gas leakage occurs.

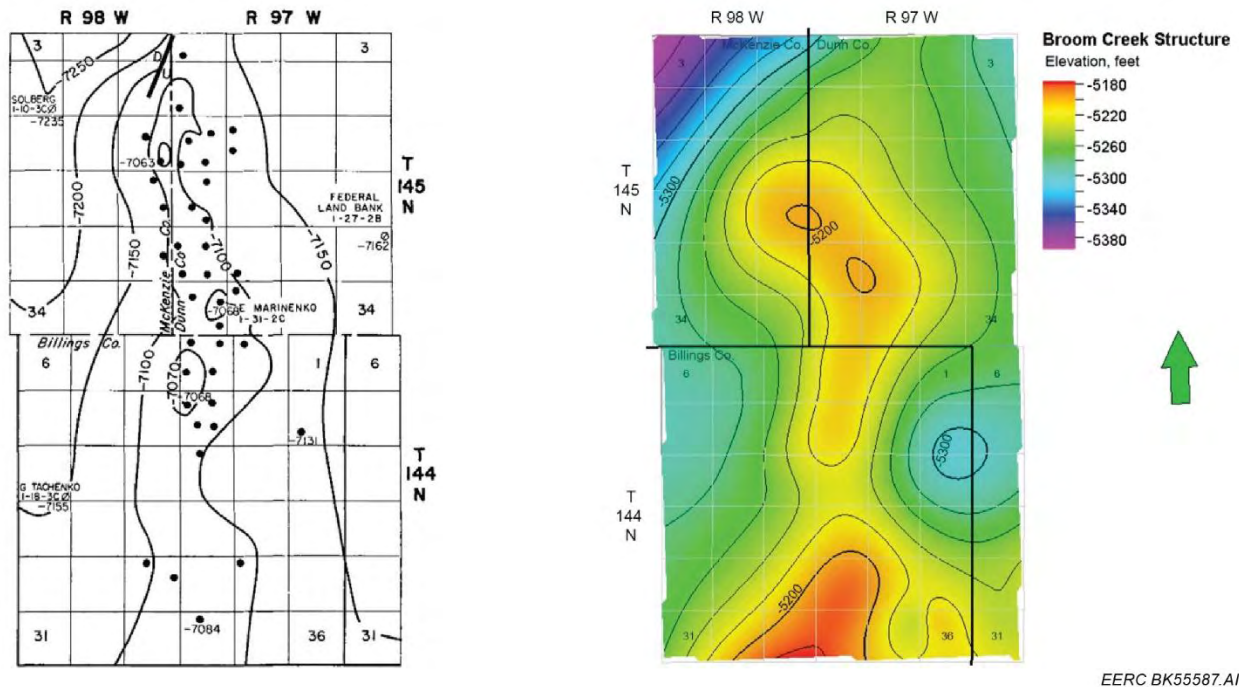

Figure 15. Little Knife Field: (left) structural contour map of the Mission Canyon top (Wittstrom and Hagemier, 1978) and (right) structure contour map of the Broom Creek top.

Potential Williston Basin Injection Targets

Figure 16 highlights the Williston Basin formations underlying North Dakota that may contain zones with the lithology and reservoir characteristics needed for produced gas injection and/or storage or, in the case of unconventional targets like the Bakken, have been engineered (i.e., hydraulically fractured) to allow for fluid flow. These storage targets include saline and hydrocarbon-bearing formations, and many formations in the Williston Basin contain zones that are filled with high-salinity brine (with no hydrocarbon content) as well as zones that are also hydrocarbon-bearing. It is important to note that there may be other formations that could serve as targets for EOR that were not identified or described herein. Instead, this effort focused on targets that have been previously identified by the EERC and others as potential storage or EOR targets using CO₂. In each case, a site-specific evaluation of the formation and its potential viability as a gas storage or EOR target would have to be performed. This summary is meant as a starting point to identify possible alternative targets and their average depth and thickness in the core Bakken area.

Although the Inyan Kara Formation (also referred to as the Dakota Sandstone) is an excellent target for brine or gas injection and storage, it was not considered as a viable target in this effort. The Inyan Kara is the primary target used for SWD in the state and, as a result, there are zones within the formation that are already experiencing significant increases in reservoir pressure (Ge and others, 2018). This increase in reservoir pressure limits injectivity of SWD wells and can cause

SYSTEM	ROCK UNIT			ROCK COLUMN	AVERAGE DEPTH FEET (METERS)	
	SERIES	GROUP	FORMATION			MEMBER
Lower	Dakota	Dakota	Mowry			
			Newcastle			
			Skull Creek			
			Inyan Kara			
JURASSIC			Swift			
			Rierdon			
			Piper	Bowen		
				Fleming		
				Tamplin		
Kline						
TRIASSIC			Peculiar			
			Bob			
			Dunkum			
PERMIAN			Saunder			
			Fine			
			Bellevue			
CARBONIFEROUS	PENNSYLVANIAN	MINNELUSA	Broom Creek		7430 (2265)	
			Amsden			
			Alaska Bench			
			Tyler		7570 (2307)	
			Otter			
	MISSISSIPPIAN	BIG SNOWY	MADISON	Kibbey		7730 (2356)
				Charles		
				Mission Canyon		9010 (2746)
				Lodgepole		9590 (2923)
				Bakken		10,340 (3152)
DEVONIAN	JEFFERSON	MANITOWA	Three Forks		10,420 (3176)	
			Birdhear			
			Duperow		10,730 (3271)	
			Souris River			
			Dawson Bay			
	ELK POINT			Moutrah		
				Belle Plaine		
				Estevan		
				Winnipegosis		11,760 (3584)
				Ashern		
SILURIAN			Interlake			
ORDOVICIAN	BIG HORN		Stonewall			
			Stony Mountain			
			Red River		13,240 (4036)	
			Roughlock			
			Icebox			
WINNIPEG			Black Island		13,990 (4264)	
			Deadwood		14,120 (4304)	
CAMBRIAN						
PRECAMBRIAN	WYOMING PROVINCE	STRUCTURAL PROVINCES TRANS-HUDSON OROGEN		SUPERIOR PROVINCE		

EERC BK5588.AI

Figure 16. North Dakota stratigraphic column highlighting potential gas storage target formations. Red boxes indicate potential saline or conventional hydrocarbon reservoir targets, and yellow boxes indicate unconventional hydrocarbon reservoirs.

pressurization problems when drilling new oil and gas wells through the Inyan Kara. Because of the current issues and competition for storage space in the Inyan Kara, the EERC did not include it as a potential gas storage target; however, it could still be a viable injection target in select areas with no current SWD activities.

All of the formations identified in Figure 16 have produced hydrocarbons from conventional or unconventional oil fields within North Dakota. There are several benefits associated with produced gas injection into an active oilfield. These formations, by default, possess the required geology to capture and contain hydrocarbons as well as sufficient porosity and permeability (in conventional reservoirs) to facilitate hydrocarbon production. These same characteristics are what are needed to successfully inject and store gas in the subsurface.

Perhaps a more significant benefit of produced gas injection into oil and gas reservoirs from a technical, economic, and regulatory perspective is the potential for EOR and pressure maintenance or repressurization. If excess produced gas is managed by using it as a driver for EOR, there are no regulatory issues related to pore space ownership because the gas is being used to improve the recovery of oil within a mineral estate. This is discussed further in the regulatory section of this document. A map of conventional oil fields (including unitized fields) that could provide opportunities for EOR using produced gas is shown in Figure 17.

Produced gas injection into unconventional formations like the Bakken and Three Forks could also provide tremendous benefit with respect to pressure maintenance and EOR; however, hydraulic fracturing of the reservoirs adds additional complexity with respect to containment and control of injected gas. Produced gas injection into unconventional targets and the complexity associated with this option are discussed as follows. For each of the potential storage targets described, a local study would be needed to identify and characterize the reservoir of interest and further determine its suitability for gas storage.

Potential Gas Injection Targets in Saline Zones or Conventional Oil and Gas Reservoirs

A summary of other potential saline and/or EOR injection targets is provided below. A more detailed description of each potential injection horizon is also provided. Much of this information is based on geologic CO₂ storage assessment work conducted by the EERC through the Plains CO₂ Reduction Partnership (funded by the U.S. Department of Energy) and other regional CO₂ storage assessment work. As part of the EERC's efforts to evaluate the viability of these formations as potential CO₂ storage targets, reservoir models for portions of several of these formations have been developed and could be used to evaluate injection, storage, and recovery of produced gas.

Deadwood Formation

The Deadwood Formation is the deepest potential gas injection target in North Dakota. The Deadwood Formation, which overlies the Precambrian basement, has an average depth of 14,120 feet and a thickness of 190 feet within the core Bakken production area (Fischer and others, 2008a). The Deadwood is capped by the shales of the Icebox Formation. The Deadwood has

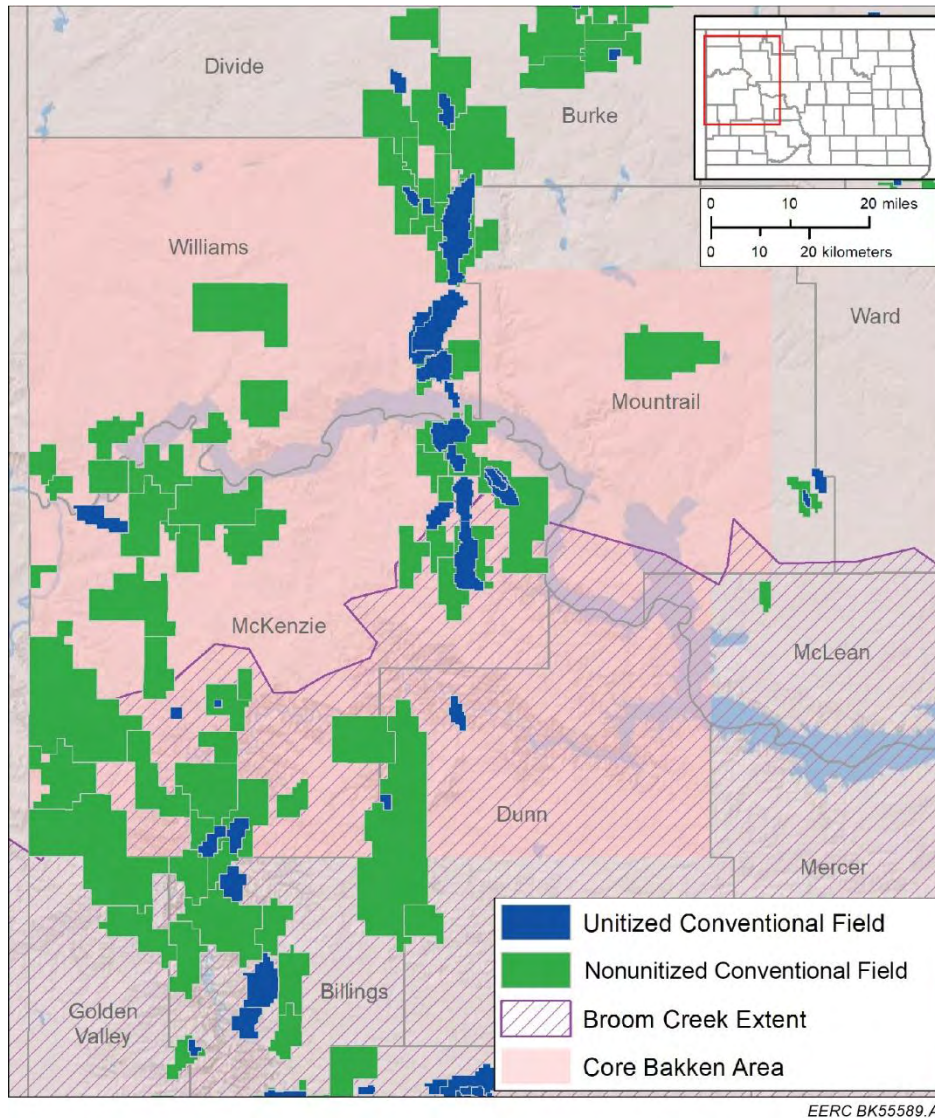

Figure 17. Map of conventional oil fields, including unitized fields, that could serve as potential gas injection targets.

produced hydrocarbons from a limited number of locations within the core Bakken area, providing potential opportunities for EOR. The Deadwood has been considered an excellent CO₂ storage target and is being used for CO₂ storage and water disposal in Saskatchewan and Alberta, Canada. The EERC has conducted regional and site-specific Deadwood Formation gas injection assessments, including the construction of geologic models and numerical simulation of injection (Dalkhaa and others, 2017a, b).

Black Island Formation

The Black Island Formation is a sandstone overlying the Deadwood Formation. The Black Island Formation depth averages 13,990 feet and thickness averages 130 feet within the core

Bakken production area (Fischer and others, 2008b). The sandstones of the Black Island have reservoir-quality porosity and permeability that could provide opportunities for gas storage. The sandstones of the formation are capped by the shales of the Icebox Formation. Similar to the Deadwood, the Black Island produces hydrocarbons from few locations in North Dakota, allowing options for both saline storage as well as EOR. Because the Black Island Formation overlies the Deadwood, both formations could potentially be utilized in a gas storage project. The Black Island is being used as a CO₂ storage target for the Aquistore project in southern Saskatchewan.

Similar to the past work on the Deadwood Formation, the EERC has conducted regional and site-specific (Aquistore) gas injection assessments of the Black Island Formation. This work included the construction of geologic models and numerical simulation of gas injection (Dalkhaa and others, 2017a, b).

Red River Formation

The Red River Formation is one of the main hydrocarbon-producing formations in North Dakota and could serve as a produced gas injection target for EOR at multiple locations in the core Bakken area. The Red River Formation averages 13,240 feet deep, with a thickness of 550 feet within the core Bakken production area (Fischer and others, 2008c). The Red River is primarily a carbonate formation. The Red River is overlain by the shales and carbonates of the Stony Mountain Formation.

The EERC has conducted field-scale assessments (Beaver Creek Field) of the Red River Formation as a gas injection and potential EOR target. This work included the construction of geologic models and numerical simulation of injection and production.

Winnipegosis Formation

The Winnipegosis Formation has an average depth of 10,760 feet and an average thickness of 170 feet within the core Bakken production area (Fischer and others, 2008d). The reservoir lithology of the formation is typically a dolostone. The best porosity and permeability of the formation usually occurs in association with patch and pinnacle reefs, which provide opportunities for both saline storage and EOR within the formation. There may be opportunities for gas storage in pinnacle reefs because of their structure and ability to contain gas in a discrete structure. One pinnacle reef is located on the northern edge of the core Bakken area, while the others are located beneath Ward, Renville, Bottineau, and McHenry Counties and do not occur within the core Bakken producing area.

The EERC has conducted multiple field-scale (Temple Field) and site-specific (pinnacle reef) Winnipegosis Formation gas injection and EOR potential assessments, including the construction of geologic models and numerical simulation of injection and production (Oster, 2016; Bosshart, 2014; Braunberger and others, 2014).

Duperow Formation

The Duperow Formation is composed mainly of carbonates with interbedded evaporites. The Duperow Formation averages 10,730 feet deep and has an average thickness of 400 feet within the core Bakken production area (Fischer and others, 2008d). Core analysis data for the formation indicate that zones of porosity and permeability suitable for gas injection and storage exist in some locations of the formation.

The EERC has conducted a field-scale (Gooseneck Field) Duperow Formation gas injection and EOR potential assessment, including the construction of geologic models and numerical simulation of injection and production.

Madison Group

The Madison Group has historically been one of the primary oil-producing formations in North Dakota, demonstrating the required porosity and permeability for produced gas storage. The abundance of conventional Madison oil fields may provide a great opportunity for EOR with Bakken produced gas.

The Madison Group consists of carbonate and evaporate facies throughout the Williston Basin of North Dakota. The Madison Group consists of three formations: the lowermost Lodgepole Formation overlain by the middle Mission Canyon Formation and the uppermost Charles Formation. Both the Lodgepole and Mission Canyon Formations are composed of carbonates with reservoir properties that could provide opportunities for produced gas storage. The Lodgepole and Mission Canyon Formations have an average depth of 9590 and 9010 feet, respectively, within the core Bakken production area. Thicknesses of the Lodgepole and Mission Canyon Formations within the core production area are 750 and 770 feet, respectively.

The EERC has conducted basin-, regional-, and field-scale (Big Stick, T.R., Fryburg, Medora, Rival, and Beaver Lodge Fields and Dickinson Lodgepole Mounds) Madison Group gas injection and EOR potential assessments, including the construction of geologic models and numerical simulation of injection and production (Burton-Kelly and others, 2018; Dotzenrod and others, 2017).

Amsden Formation

The Amsden Formation, directly underlying the Broom Creek Formation, extends from southwestern North Dakota northward to the Nesson Anticline near Tioga, North Dakota. Pre-Jurassic erosion removed Amsden deposits north of the center of the anticline. The Amsden Formation is not known to contain economical reserves of hydrocarbons, but nitrogen gas pockets have been discovered in several fields (Charlson, Antelope, Blue Butte, Hawkeye, and Clear Creek Fields) along the Nesson Anticline (Marchant, 1966), suggesting the formation may serve as an effective trap if considered for produced gas storage.

Nitrogen-bearing Amsden intervals along the Nesson occur at a depth of approximately 7100 feet, generally vary in thickness from 150 to 350 feet, and are predominantly

cryptocrystalline to fine-grained dolomite with shale interbeds. Varying amounts of gray to red, calcareous or dolomitic, fine-grained sandstone are also present.

Kibbey Formation

The Mississippian Kibbey Formation has an average depth of 7730 feet and an average thickness of 200 feet. It comprises primarily medium-grained sandstone, limestone, and shale. Historically, the Kibbey has not been widely targeted for oil production, although some oil production has occurred in the Red Wing Creek Field. The Kibbey is overlain by the shale and limestone of the Otter Formation of the Big Snowy Group.

Potential Unconventional Reservoir Injection Targets

The most likely injection targets for EOR in unconventional oil and gas reservoirs include the Bakken, Three Forks, and Tyler Formations. The appeal of injecting gas into an unconventional target lies in the benefits associated with maintaining reservoir pressure and thereby slowing the steep rate of production decline that is common in unconventional systems. Despite the benefits associated with pressure maintenance and improved oil recovery, injection of gas into hydraulically fractured reservoirs can be difficult to manage and has yet to be widely implemented. An analysis of historical pilot-scale EOR tests in the Bakken has shown that keeping the injected gas in the target reservoir long enough for it to mobilize incremental oil (e.g., “conformance”) is a significant challenge for EOR operations in tight oil reservoirs (Sorensen and Hamling, 2016).

The EERC has conducted basin- and field-scale Bakken–Three Forks Formation and field-scale Tyler Formation (Fryburg and Medora Fields) gas injection and EOR potential assessments, including the construction of geologic models and numerical simulation of injection and production (Jin and others, 2017; Sorensen and others, 2018; Torres and others, 2018a, b). The EERC is working with Liberty Resources (LR) to design and conduct an EOR pilot test using rich gas as the injection fluid. One of the primary goals of the pilot test is to develop operational approaches that cost-effectively manage conformance of the injected gases within the target reservoir. Rich gas injection testing was initiated in summer 2018 and is expected to continue until summer 2019. Results of this pilot test are expected to be available by the end of 2019 and will help inform future gas injection initiatives within the Bakken.

CONSIDERATIONS FOR PRODUCED GAS STEWARDSHIP

There are many factors that can impact the viability of gas injection, including regulatory, economic, legal, and logistical factors. These factors should be taken into account when considering the best potential options to meet gas capture requirements. The following section provides an overview of these factors and their potential effects on gas injection projects.

Logistical, Economic, and Legal Considerations

Scale and Duration

Gas injection into geologic formations may necessitate larger scale than other alternate gas use approaches given the capital investment needed for the surface facilities and gas and water injection wells. Additionally, because of the large equipment and permanent facilities (injection wells) required to implement gas injections projects, stranded gas must be available for long periods of time, ideally many years. Identifying production locations with large, long-duration stranded gas volumes will be critical to cost-effectively siting and operating long-term gas storage. Many more (thousands) locations with flared gas, have insufficient gas volumes or flare duration to qualify for on-site gas injection. There is the possibility of aggregating gas from multiple locations to achieve the necessary scale to enable gas injection. However, the economics of such an effort would have to be evaluated. Alternatively, if produced gas injection and storage were planned proactively to allow for development of additional wells on a DSU where gas capture is constrained, the potential gas volumes needed for storage could be better estimated and the storage site designed accordingly.

Planning and Timing

The fixed-capital investment to execute a gas injection project includes both skid-mounted (and therefore movable) equipment, but also permanent infrastructure including a gas injection well and a water disposal well. All of these items (compressors and wells) require engineering design, permitting, and procurement activities, which necessitates a minimum 1-year lead time. Therefore, 1 year before a set of wells is scheduled to begin production, planning and financial commitment for gas injection must begin. Thus the concept of produced gas injection to avoid curtailed oil production is probably best applied in a proactive manner to facilitate the development of additional wells in areas where gas capture capacity is already constrained and likely to remain so for several years or longer.

Competing Alternative Gas Use Technologies

A variety of alternate gas use technologies exist which can utilize stranded gas at wellsites and aid in reducing gas flaring. Analysis of their use has been studied by the EERC and is available at www.undeerc.org/flaring_solutions/Files-Reports.aspx. These technologies generally fall into the categories of gas-fired electrical generation, wellsite NGL recovery, processing to CNG or LNG to provide fuel to off-site heating or electrical generators, and small-scale conversion to chemicals or fuels. These technologies are challenged by the same factors described earlier in this report, namely flare gas quality, quantity, and transience. Nonetheless, the cost and mobility of some of these alternate gas use technologies may provide advantages over geologic storage for some applications while providing similar flare mitigation benefit relative to achieving gas capture targets and minimizing curtailed oil production. This is especially true for the relatively larger-scale, longer-duration stranded gas scenarios considered for this study.

Gas Contracts with Midstream Companies

At production locations with gas-gathering infrastructure, producers may be contractually obligated to provide their gas to midstream service providers as long as sufficient pipeline capacity is available. These gas contracts for long-term supply of associated gas are the mechanism that enables investment in gas-gathering pipelines, compression, and gas-processing plants. Consideration must be given to the nature of these contracts when contemplating alternative uses. For example, if a producer invests in a gas storage project as a means of capturing flare gas but pipeline capacity becomes available, the producer may become contractually obligated to provide the requisite volume of gas to the midstream service provider prior to subsurface injection.

Regulatory Considerations

From a regulatory standpoint, several factors need to be considered if produced gas were to be injected into the subsurface. Fundamentally, the specifics of regulatory oversight regarding stewardship of the produced gas will depend on the nature of the approach taken. In the North Dakota portion of the Williston Basin, there are two principal target categories, each with an associated regulatory framework: deep saline formations (DSFs) and depleted oil/gas-producing reservoirs (Figure 18). Regulatory considerations for these two produced gas stewardship approaches are presented in this section, specifically including 1) temporary storage of the produced gas in a deep saline formation, and 2) using the produced gas as an enhanced oil recovery fluid in North Dakota's legacy (conventional) oil fields.

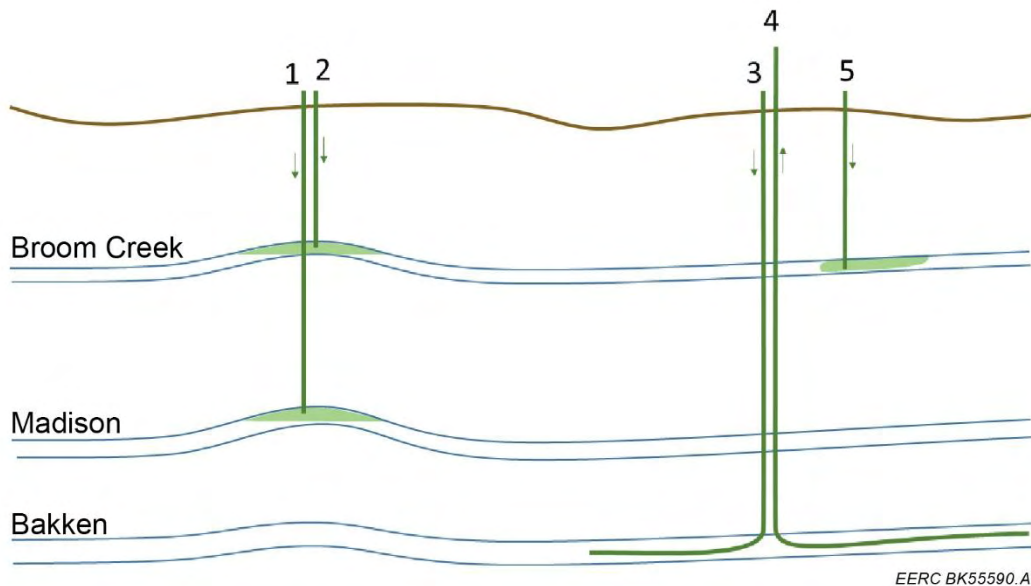

Figure 18. Produced gas injection scenarios: 1) EOR in depleted oil field, 2) storage in saline formations (structural traps), 3) injection back into Bakken, 4) production wells, and 5) storage in saline formations (no structural traps).

Storage in DSFs

Although North Dakota currently has no specific regulations regarding the temporary storage of produced gas, there are statutes that parallel the idea of produced gas storage, specifically, the long-term storage of CO₂ and SWD. As detailed in North Dakota Century Code (NDCC) §38-08-04-01(b)(6), NDIC has the authority to regulate the underground storage of oil or gas. In addition, NDIC has authority (and a duty) to investigate whether waste exists or is imminent or whether other facts exist that justify action by NDIC.

The injection of produced gas back into the subsurface for the purpose of storage requires a target horizon with sufficient injectivity (a function of porosity and permeability). The receiving formation needs to efficiently accept and store the injected gas. Portions of DSFs that do not contain hydrocarbon resources are located at various depths and lateral extents in the Williston Basin. Some examples include the sandstones of the Deadwood, Black Island, Kibbey, and Broom Creek Formations. Storage of produced gas in a DSF entails injecting the gas into the reservoir and displacing a portion of the saltwater existing in the pore spaces. According to North Dakota statute (NDCC §47-31-03), this pore space resource is “vested in the owner of the overlying surface estate.” Although not yet formally defined, regulatory oversight of produced gas storage in the pore space of DSF may involve acquiring legal permission to access (lease) the pore space. In addition, sufficient investigation may be required to document where the injected gas will migrate and assure there are no migration pathways for the injected gas to move out of the target horizon. The latter requirements will be based on reservoir modeling and simulation.

Based on a 10-MMscf/day injection rate over the course of several months, a resulting produced gas plume could grow into a roughly circular area nearly 1 mile in diameter. At this size, the plume likely underlies more than one landowner and thus more than one pore space owner (Figure 19a and b). In this situation, the required pore space needs to be amalgamated, a process similar to unitization in oil fields. Based on North Dakota’s CO₂ underground storage statute, amalgamation can proceed if the storage operator has obtained the consent of persons who own at least 60% of the storage reservoir’s pore space needed for the project (NDCC §38-22-08-5).

In the Broom Creek case study, the key considerations include compensation of the surface owners for their pore space, timing of royalty payments to the mineral owners (preinjection or postrecovery and sale), and ownership of any unrecovered gas from the subsurface formation.

A list of potential guidelines for a produced gas storage permit application has been drafted by the NDIC Oil and Gas Division; a subset of that list is presented below. These items are drawn from existing regulations regarding the long-term storage of CO₂ and represent a starting point for the development of a permitting procedure for the injection of produced gas into a storage horizon:

- Petition for a hearing.
- Notification of each operator of mineral extraction activities within the plume area.
- Notification of each owner and lessee of record of minerals within the plume area.
- Permits for well(s) and surface facilities.
- Affidavit certifying all pore space owners and lessees within the plume area have been notified.

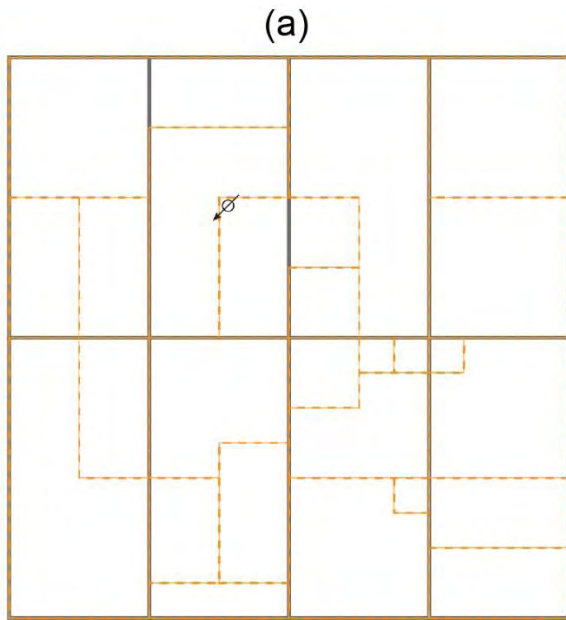

Produced gas injector surrounded by 1280-acre drill spacing units (DSUs) overlain by landownership division (dashed rectangles).

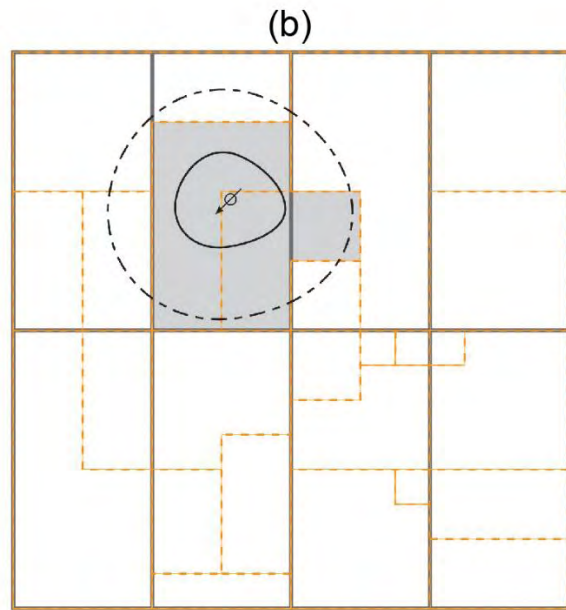

Produced gas storage facility area (solid oval) represents the extent of pore space that will be occupied by the injection and geologic storage of produced gas over the life of the project.

Area of review (dashed oval = half-mile buffer around the gas storage facility area).

Gray area represents landowners to be included in the pore space amalgamation process.

0 1 mile

EERC BK55591.AI

Figure 19. Visual representation of pore space amalgamation considerations with respect to landowners within a given gas storage project area.

- Map showing the extent of pore space that will be occupied by the storage of produced gas over the life of the project.
- Geologic exhibits (e.g., structure and isopach maps, structural spill points, geomechanical information).
- Inventory and status of all wells (water, oil, other) within the plume area and a ½-mile buffer of that area (i.e., area of review [see Figure 19b]).
- Well construction and plugging information within the area of review.
- Leak detection and monitoring plan for all surface facilities.
- Leak detection and monitoring plan to identify any movement of the produced gas outside of the intended target formation.

Because the reinjection of produced gas into a non-hydrocarbon-bearing formation has not yet occurred in North Dakota, regulatory clarity for some of these aspects, such as compensation for pore space utilization, does not yet exist.

Produced Gas Injection into Conventional Oil Reservoirs

Excess produced gas from a DSU or series of DSUs could be gathered and used (or sold if the market exists) as a working fluid for EOR in one of North Dakota's conventional oil fields. This approach would be regulated by well-established North Dakota statutes and avoid issues of pore space ownership and other storage-related guidelines. Of particular note would be the requirement to unitize the oilfield reservoir in cases where that effort had not already been under taken. Unitization refers to organizing (geologically and legally) oil fields into larger working areas (units) for the purpose of secondary and tertiary recovery operations. Unitization ensures the correlative rights of all mineral owners within the designated area are protected, net revenues are apportioned among those with interests in the field, and injection and reservoir management practices are coordinated to improve the efficiency of petroleum extraction (Sorensen and others, 2009). Precedence has been set in the state for this type of activity. The Red Wing Creek, Dolphin, and Stoneview unitized fields have received injected hydrocarbon gas for EOR (Stright and Fallin, 1992; Pickard 1994; Williams and Pitts, 1997).

Produced Gas Injection into the Source Formation

Injection of the associated gas back into the producing horizon in a nominally closed-loop system would eliminate the need for royalty payments to the mineral owner and payment of extraction taxes to the state because the natural gas was not "produced." This scenario requires that the produced gas be injected into the producing horizon within the DSU from which it was drawn to protect correlative rights of neighboring DSUs. To ensure that neighboring spacing units are not affected by the injection activity, monitoring of the boundary production wells may be necessary. In addition, some type of approach would be necessary to ensure that produced gas injected near the heel or toe of a horizontal well would not migrate into neighboring DSUs.

DISCUSSION AND CONCLUSIONS

The results of this effort suggest that the concept of subsurface gas injection for produced gas management and to achieve gas capture requirements may be economically viable. A broad estimate of capital costs for a site designed to inject produced gas into the Broom Creek Formation at a rate of 10 MMscf/day was \$15.7 million, or \$2.15/Mcf based on the cumulative volume of injected gas at an injection rate of 10 MMscf/day for 2 years. The operational costs were not calculated in detail but could add another \$2 million, excluding taxes and royalty payments.

The capital costs would be offset by the benefits associated with unconstrained oil production. Basinwide estimates of the potential value of the oil that is currently being voluntarily curtailed range from \$3 to \$4.7 million/day (based on oil prices of \$59/bbl). If temporary subsurface gas storage was implemented at a site and injection occurred at a rate of 10 MMscf/day for 2 years (to accommodate the average produced gas volume from five wells), the value of the generated oil could be as high as \$200 million over a 2-year period. Even if the dynamics of gas-gathering capacity resulted in a 50% reduction of the gas volume available for injection, the enabled oil production would still have a value of approximately \$100 million. When compared to the broad estimate of capital and operational costs (excluding production tax and royalty payments), the potential benefit is still significantly larger than the costs to establish and operate a gas injection facility. In this case, using the “typical” gas production from a Bakken well for the first 2 years of production and assuming gas injection from five wells on a site, the capital cost is estimated at \$2.41/Mcf of injected gas. It is important to note that gas capture is complex and many options exist that can reduce the quantity of “stranded” gas available at a wellsite and the associated economic benefit from geologic storage. These options were not included in the above analysis and include exemption of 60-day initial production from gas capture requirements, gas capture carryover credits, CNG and LNG credits, stranded gas designation, and force majeure exemptions. Considering the multitude of factors influencing gas capture determination and impact on oil production, a site-specific analysis is critical to evaluating the economic benefit of any particular scenario.

The most economically favorable gas *storage* option evaluated through this effort using reservoir simulation was cyclic gas injection into the same storage target. The scenario assumed that to fully develop a DSU, new wells would be developed and come online in batches of five, with 4 years of gas injection and recovery between each batch of wells. If three cycles of gas injection occurred at a rate of 10 MMscf/day for 2 years followed by 2 years of gas recovery, the gas recovery factors were estimated at approximately 50% after the first 2-year recovery period, 57% after the second period, and 63% after the third period. Rates of water production decreased with each subsequent cycle, with a production rate of approximately 2750 bbl/day after the first 2-year recovery period and decreasing to a high of 2000 bbl/day at the end of the third 2-year recovery period. Thus, with cycles of gas injection and recovery into the same storage target, gas recovery increases with each subsequent cycle, while water production decreases. This approach could significantly shorten the period of time needed to fully develop the planned wells on pads that are constrained by limited gas capture infrastructure by providing a mechanism to store excess gas. Having the option for subsurface gas storage on-site also provides the producer with the agility to better handle fluctuations in wellsite gas production and/or pipeline capacity upsets without significant interruptions in oil production. In addition, the capital cost for this approach is spread

over three gas injection and recovery operations, lowering the cost to \$0.72/Mcf based on the volume of gas that would be injected at a rate of 10 MMscf/day for three 2-year injection periods.

In some cases where anticipated future gas production volumes from a single DSU are not high enough to justify the capital costs for subsurface injection (or alternative options to meet gas capture requirements), it might be advantageous to unitize two or more DSUs. Most DSUs within the Bakken are 1280 acres in area (1 mile × 2 miles); however, it is not uncommon to find spacing units of 2560 acres or larger. These larger units are created for the efficient development and operation of the spacing unit and to prevent waste and protect correlative rights. From the standpoint of managing produced gas, the larger spacing units could be advantageous in that the larger volumes of produced gas (assuming insufficient gas capture infrastructure) could justify larger capital expenditures for alternatives, given the potential additional revenue from unconstrained oil production. The larger DSU spacing would also expand the boundaries for produced gas injection plumes and thus provide some leeway with respect to subsurface injection operations that are constrained by the DSU boundaries (such as injection into the Bakken).

One of the biggest unknowns associated with produced gas injection into saline aquifers, such as Broom Creek, is the regulatory framework for gas injection into non-hydrocarbon-bearing formations. Additional regulatory clarity regarding pore space ownership and potential landowner reimbursements for pore space use is needed, as this could impact the economics of the operation as well as the permitting process.

The regulatory framework regarding produced gas injection into oil-bearing formations is better defined, and it circumvents the need for regulatory clarity with respect to pore space ownership. The economics may also be even more favorable with this approach as a result of the additional revenue derived from any incremental oil recovery on-site. If the Bakken or Three Forks Formation was the target, the injection of produced gas back into the producing horizon would eliminate the need for royalty payments to the mineral owner and payment of extraction taxes to the state. The key challenge with gas injection into a fractured, unconventional oil target is conformance or controlling the movement of gas within the productive zone.

Gas injection into conventional oil fields for EOR is advantageous in that many of the fields have already undergone secondary recovery and, thus, are unitized. Also, many fields in the state (unitized or not) may benefit from tertiary oil recovery which has likely been constrained by a shortage of gas for use in EOR operations. Precedence for the concept of hydrocarbon gas injection into conventional fields has already been established through projects located in the Red Wing Creek, Dolphin, and Stoneview oil fields. A basic economic benefit summary of the EOR operation in the Red Wing Creek oil field suggested that even at a much smaller scale of gas injection, an additional \$29.5 million worth of incremental oil was recovered from the field.

Ultimately, the various options for produced gas capture will need to be evaluated on a case-by-case basis to determine which scenarios are the most cost-effective and least complicated from a technical, regulatory, and legal standpoint. There are many factors that impact the viability of any alternative gas use option, and site-specific conditions vary widely across the Bakken. Potential options for future work to better define the various scenarios to achieve the desired gas capture requirements are discussed as follows.

FUTURE WORK

Many potential flaring mitigation techniques as well as subsurface storage or injection for use in EOR exist to help achieve gas capture targets. However, there is no single option that will work in all locations because of varying geology, the dynamic nature of flaring, and the state of current and planned gas capture infrastructure. There are multiple avenues of additional work to better define the details of the various gas capture options, including the economic and technical viability and potential regulatory and legal constraints. Potential future activities include evaluation of potential gas capture alternatives, additional modeling and simulation activities to assess other potential saline storage targets and to evaluate the possible EOR benefits and economics of gas injection into conventional and unconventional oil reservoirs, and pilot-scale projects to better evaluate potential gas storage options in saline aquifers.

An evaluation of the economics of alternative approaches to achieve gas capture requirements is warranted, given the estimated capital and potential operational costs associated with subsurface gas injection. Potential alternatives include electrical generation, wellsite NGL recovery, compression and/or liquefaction of natural gas for use as a generator or transportation fuel, conversion to a chemical or fuel, or value-added processes that reduce the volume or intensity of the flare by greater than 60%. Although the EERC performed an analysis of these options in 2013, produced gas volumes have increased significantly since that time, plus the value associated with oil production curtailment escalates the potential benefit of alternative gas capture options.

Over the past decade, the EERC has developed several geologic and numerical simulation models through research efforts focused on the evaluation of potential CO₂ storage targets as well as reservoirs for CO₂-based EOR. These models could be expanded and/or modified to allow for additional reservoir simulation activities to assess alternative saline injection targets for gas storage and/or to better assess various conventional oil fields for possible EOR opportunities. Additional work is needed to better assess the volumes of produced gas that might be needed in conventional oil reservoirs for EOR, which, if coupled with modeling and simulation activities, would help identify promising targets and the potential volumes of incremental oil that could be recovered. A detailed review of the projects that have used hydrocarbon gas for EOR in conventional oil fields is also warranted, including a summary of the regulatory precedent established through those efforts.

Use of excess produced gas from Bakken–Three Forks wells as pressure maintenance within the DSU also warrants further investigation. For wellsites where a parent well(s) has produced for many years and significant infill drilling is planned, gas reinjection into a parent well may provide multifaceted benefits. In this scenario, large gas volumes could be captured before reaching the constrained gathering system (or flare); pressure supplied to the oil-bearing formations via the parent well, potentially enhancing primary oil production; and on-lease use of the gas may minimize impacts to royalties, taxes, and allocations. Low recovery factors from the Bakken (<10%) incentivize the application of any techniques or technologies that could increase recovery. While achieving conformance of the injected gas within the Bakken may present a challenge, with several hundred billions of barrels in place, even a small (1%) increase in oil recovery could result in a billion barrels or more of incremental oil recovery (Energy Information Administration, 2013).

From a gas storage perspective, a pilot project to demonstrate produced gas injection into a subsurface storage target would be highly beneficial to better define the permitting process, evaluate gas injectivity, assess the performance of high-pressure compressors for rich gas injection, evaluate gas and water recovery rates, and better define the technical, economic, and regulatory components of the approach. The preferred approach would be for the EERC to team with one or more Bakken producers that are interested in the concept of subsurface gas injection and storage.

REFERENCES

- Bennion, B., and Bachu, S., 2005, Relative permeability characteristics for supercritical CO₂ displacing water in a variety of potential sequestration zones in the Western Canada sedimentary basin, SPE 95547, SPE Annual Technical Conference and Exhibition, Dallas, Texas, October 9–12.
- Berger, L.C., and Arnoult, J.P., 1989, Production of inert gas for partial replacement of natural gas trapped in an underground aquifer storage reservoir: Society of Petroleum Engineers, doi:10.2118/19089-MS.
- Bismarck Tribune, 2018, North Dakota oil production sets more records, but limited by gas capture, October 12: https://bismarcktribune.com/bakken/north-dakota-oil-production-sets-more-records-but-limited-by/article_07378c45-1265-50d7-b292-8238b538da75.html (accessed December 2018).
- Bosshart, N.W., 2014, Characterization, diagenesis, and geocellular modeling of Winnipegosis Formation Pinnacle Reefs in the Williston Basin, North Dakota: M.S. Thesis, University of North Dakota, Grand Forks, North Dakota.
- Braunberger, J.R., Bosshart, N.W., Klenner, R.C.L., Liu, G., Peck, W.D., and Gorecki, C.D., 2014, Characterization and 3-D modeling of Devonian pinnacle reefs for CO₂ storage and enhanced oil recovery: Presented at the 2014 Rocky Mountain Section American Association of Petroleum Geologists Annual Meeting, Denver, Colorado, July 20–22.
- Burton-Kelly, M.E., Dotzenrod, N.W., Feole, I.K., Peck, W.D., He, J., Butler, S.K., Kurz, M.C., Kurz, B.A., Smith, S.A., and Gorecki, C.D., 2018, Identification of residual oil zones in the Williston and Powder River Basins: Final report for U.S. Department of Energy National Energy Technology Laboratory Cooperative Agreement No. DE-FE0024453, EERC Publication 2018-EERC-03-05, Grand Forks, North Dakota, Energy & Environmental Research Center, March.
- Computer Modelling Group, 2018, GEM User Guide, Computer Modelling Group.
- Dalkhaa, C., Pekot, L.J., Jiang, T., Oster, B.S., Bosshart, N.W., and Nickel, E., 2017a, Updated numerical modeling and simulation study of the Aquistore CO₂ storage project: Poster presented at the Aquistore Project 2017 Annual General Meeting, Ottawa, Ontario, September 12–13.

Dalkhaa, C., Pekot, L.J., Jiang, T., Oster, B.S., Bosshart, N.W., Sorensen, J.A., and Gorecki, C.D., 2017b, Aquistore CO₂ storage project—numerical modeling and simulation update: Plains CO₂ Reduction (PCOR) Partnership Phase III Task 1 Deliverable D93 Update 3 for U.S. Department of Energy National Energy Technology Laboratory Cooperative Agreement No. DE-FC26-05NT42592, EERC Publication 2017-EERC-10-08, Grand Forks, North Dakota, Energy & Environmental Research Center, October.

Dotzenrod, N.W., Dalkhaa, C., Pekot, L.J., He, J., Burton-Kelly, M.E., Feole, I.K., Bosshart, N.W., Peck, W.D., Ayash, S.C., and Gorecki, C.D., 2017, Fine-scale modeling and simulation of the Bigstick and T.R. Fields, North Dakota, (update): Task 6 Deliverable D8 for U.S. Department of Energy National Energy Technology Laboratory Cooperative Agreement No. DE-FE0024453, EERC Publication 2017-EERC-11-02, Grand Forks, North Dakota, Energy & Environmental Research Center, November.

Energy Information Administration, 2013, Technically recoverable shale oil and shale gas resources—an assessment of 137 shale formations in 41 countries outside the United States: U.S. Department of Energy Washington, D.C., www.eia.gov/analysis/studies/worldshalegas/pdf/fullreport.pdf (accessed 2013).

Energy Information Administration, 2017

Energy Information Administration, 2018, Data and information derived from the following site: www.eia.gov/naturalgas/ngqs/#?report=RP7&year1=2017&year2=2017&company=Name (accessed November 2018).

Fischer, D.W., LeFever, J.A., LeFever, R.D., Helms, L.D., Sorensen, J.A., Smith, S.A., Steadman, E.N., and Harju, J.A., 2008a, Duperow Formation outline: value-added topical report for U.S. Department of Energy Cooperative Agreement No. DE-FC26-05NT42592, Grand Forks, North Dakota, Energy & Environmental Research Center, March.

Fischer, D.W., LeFever, J.A., LeFever, R.D., Helms, L.D., Sorensen, J.A., Smith, S.A., Steadman, E.N., and Harju, J.A., 2008b, Red River Formation outline: Plains CO₂ Reduction (PCOR) Partnership value-added topical report for U.S. Department of Energy National Energy Technology Laboratory Cooperative Agreement No. DE-FC26-05NT42592, Grand Forks, North Dakota, Energy & Environmental Research Center, March.

Fischer, D.W., LeFever, J.A., LeFever, R.D., Helms, L.D., Sorensen, J.A., Smith, S.A., Steadman, E.N., and Harju, J.A., 2008c, Winnipegosis Formation outline: value-added topical report for U.S. Department of Energy Cooperative Agreement No. DE-FC26-05NT42592, Grand Forks, North Dakota, Energy & Environmental Research Center, March.

Fischer, D.W., Sorensen, J.A., Smith, S.A., Steadman, E.N., and Harju, J.A., 2008d, Black Island Formation outline: Plains CO₂ Reduction (PCOR) Partnership value-added topical report for U.S. Department of Energy National Energy Technology Laboratory Cooperative Agreement No. DE-FC26-05NT42592, Grand Forks, North Dakota, Energy & Environmental Research Center, March.

Fischer, D.W., Sorensen, J.A., Smith, S.A., Steadman, E.N., and Harju, J.A., 2008e, Deadwood Formation outline: Plains CO₂ Reduction (PCOR) Partnership value-added topical report for

U.S. Department of Energy National Energy Technology Laboratory Cooperative Agreement No. DE-FC26-05NT42592, Grand Forks, North Dakota, Energy & Environmental Research Center, March.

Ge, J., Bosshart, N., Pekot, L., Kurz, B., Gorecki, C., He, J., and Oster, B., 2018, Modeling and simulation of the Inyan Kara Formation to estimate saltwater disposal potential. Final report prepared for the Members of the Bakken Production Optimization Program and the North Dakota Industrial Commission. EERC Report Number 2018-EEERC-06-06. 40 pp.

Jin, L., Hawthorne, S.B., Sorensen, J.A., Pekot, L.J., Bosshart, N.W., Gorecki, C.D., Steadman, E.N., and Harju, J.A., 2017, Utilization of produced gas for improved oil recovery and reduced emissions from the Bakken Formation: Presented at the 2017 Society of Petroleum Engineers (SPE) Health, Safety, Security, Environment & Social Responsibility Conference North America, New Orleans, Louisiana, April 18–20, SPE-184414-MS.

Katz, D.L., and Tek, M.R., 1981, Overview on underground storage of natural gas: Society of Petroleum Engineers. doi:10.2118/9390-PA, June 1.

Knudsen, D.J., Bremer, J.M., Gorecki, C.D., Sorensen, J.A., Peck, W.D., Harju, J.A., and Steadman, E.N., 2009, Task 1 Deliverable D2 – Plains CO₂ Reduction (PCOR) Partnership (Phase III) – site characterization of the Dickinson Lodgepole Mounds for potential CO₂ enhanced oil recovery: Final report (October 1, 2007 – September 30, 2009) for U.S. Department of Energy National Energy Technology Laboratory Cooperative Agreement No. DE-FC26-05NT42592, EERC Publication 2010-EERC-03-02, Grand Forks, North Dakota, Energy & Environmental Research Center, May.

Marchant, L.C., 1966, Nitrogen gas in five oil fields on the Nesson Anticline in North Dakota: U.S. Department of the Interior – Bureau of Mines, Report of Investigations 6848.

Nordeng, S.H., and Helms, L.D., 2010, Bakken source system – Three Forks Formation assessment: North Dakota Department of Mineral Resources, 22 p., April.

North Dakota Industrial Commission, 2018a, Case Number 2205: www.dmr.nd.gov/oilgas/FeeServices/wfiles/c02/C2205.pdf (accessed December 2018).

North Dakota Industrial Commission, 2018b, Case Number 4386: www.dmr.nd.gov/oilgas/FeeServices/wfiles/c04/C4386.pdf (accessed December 2018).

North Dakota Industrial Commission, 2018c, November 2018 director's cut: www.dmr.nd.gov/oilgas/directorscut/directorscut-2018-11-16.pdf (accessed November 2018).

Oster, B.S., 2016, Reservoir characterization and modeling—Winnipegosis Formation, Temple Field, Williston Basin, North Dakota: M.S. Thesis, University of North Dakota, Grand Forks, North Dakota.

Peters, M.S., and Timmerhaus, K.D., 1991, Plant design and economics for chemical engineers, 4th edition: New York, McGraw-Hill, Inc.

- Pickard, C.F., 1994, Twenty years of production from an impact structure, Red Wing Creek Field, McKenzie County, North Dakota, Paper presented at the Annual AAPG–SEPM–EMD–DPA–DEG Convention, Denver, 12–15 June, 234.
- Pollastro, R.M., Roberts, L.N.R., and Cook, T.A., 2012, Geologic model for the assessment of technically recoverable oil in the Devonian–Mississippian Bakken Formation, Williston Basin, *in* J.A. Breyer, ed., *Shale reservoirs–Giant resources for the 21st century: AAPG Memoir 97*, p. 205–257.
- Schlumberger, 2016, Petrel 2016: Petrel E&P software platform.
- Sorensen, J.A., Botnen, L.S., Steadman, E.N., Harju, J.A., Helms, L.D., and Fischer, D.W., 2009, Unitization of geologic media for the purpose of monetizing geologic sequestration credits, *in* carbon dioxide sequestration in geological media – state of the science, Grobe, M., Pashin, J.C., and Dodge, R.L., Eds.: *AAPG Studies in Geology 59*, Tulsa, Oklahoma, American Association of Petroleum Geologists, p. 707–715.
- Sorensen, J.A., and Hamling, J.A., 2016, Historical Bakken test data provide critical insights on EOR in tight oil plays: *The American Oil & Gas Reporter*, v. 59, no. 2, p. 55–61, February.
- Sorensen, J.A., Hawthorne, S.B., Jin, L., Bosshart, N.W., Torres, J.A., Azzolina, N.A., Kurz, B.A., Smith, S.A., Jacobson, L.L., Doll, T.E., Gorecki, C.D., Harju, J.A., and Steadman, E.N., 2018, Bakken CO₂ storage and enhanced recovery program – Phase II: Final report for U.S. Department of Energy National Energy Technology Laboratory Cooperative Agreement No. DE-FC26-08NT43291, XTO Energy, Hess Corporation, Marathon Oil Company, Continental Resources, and North Dakota Industrial Commission Oil & Gas Research Program, Grand Forks, North Dakota, Energy & Environmental Research Center, April.
- Stright, D.H. Jr., and Fallin, W.S., 1992, Dolphin Field—a successful miscible gas flood in a small volatile oil reservoir: Paper SPE 2433 presented at the SPE Rocky Mountain Regional Meeting, Casper, Wyoming, May 18–21, DOI: 10.2118/24333-MS.
- Torres, J.A., Jin, L., Bosshart, N.W., Feole, I.K., Pekot, L.J., Sorensen, J.A., and Hawthorne, S.B., 2018a, CO₂ storage and enhanced oil recovery in tight oil formations—insights from laboratory investigations and field-scale simulations: Presented at the InterPore 10th Annual Meeting and Jubilee, New Orleans, Louisiana, May 14–17.
- Torres, J.A., Jin, L., Bosshart, N.W., Pekot, L.J., Sorensen, J.A., Peterson, K., Anderson, P.W., and Hawthorne, S.B., 2018b, Multiscale modeling to evaluate the mechanisms controlling CO₂-based enhanced oil recovery and CO₂ storage in the Bakken Formation: Paper presented at the Unconventional Resources Technology (URTeC) Conference, Houston, Texas, July 23–25, URTeC Paper No. 2902837.
- Williams, E.T., and Pitts, M., 1997, Application of enhanced oil recovery in the Rocky Mountain Region: *Innovative applications of petroleum technology guidebook*, p. 225–240.
- Wittstrom, M.D., and Hagemeyer, M.E., 1978, A river of Little Knife Field development, North Dakota, 1978 Williston Basin Symposium: *The economic geology of Williston Basin*, p. 361–368.

APPENDIX A

SIMULATION OF PRODUCED GAS INJECTION INTO THE BROOM CREEK FORMATION

SIMULATION OF PRODUCED GAS INJECTION INTO THE BROOM CREEK FORMATION

To evaluate the feasibility of produced gas injection and recovery into a subsurface saline geologic target, a reservoir simulation model of the Broom Creek Formation was developed. The reservoir model was constructed by coupling a geologic model developed using Schlumberger's Petrel E&P software platform (Schlumberger, 2016) with numerical simulation software developed by Computer Modelling Group (CMG) (Computer Modelling Group, 2018). Once developed, the reservoir model was used to evaluate a variety of different gas injection and recovery scenarios, which are discussed further in subsequent sections of this report.

The Broom Creek Formation is a Permian-age saline aquifer that comprises primarily sandstone and carbonate (dolostone) and occurs at an average depth of 7400 feet in the core Bakken production area. The Broom Creek was selected as a target for simulation of produced gas injection and storage because of the existence of a recently developed reservoir model by the Energy & Environmental Research Center (EERC) that was designed to evaluate CO₂ injection into the subsurface. While the Broom Creek is a specific injection target, the thought was that the results of the simulation effort would provide insight regarding the feasibility of produced gas injectivity, subsurface gas migration, and gas recovery into similar geologic targets within the Williston Basin.

GEOLOGIC MODEL DEVELOPMENT

A Broom Creek Formation geologic model was used to evaluate the injection, storage, and subsequent production of hydrocarbon gas. The model represented a 500-mi² (25-mi × 20-mi) area in Dunn and McKenzie Counties, centered on Little Knife Field (Figure A-1).

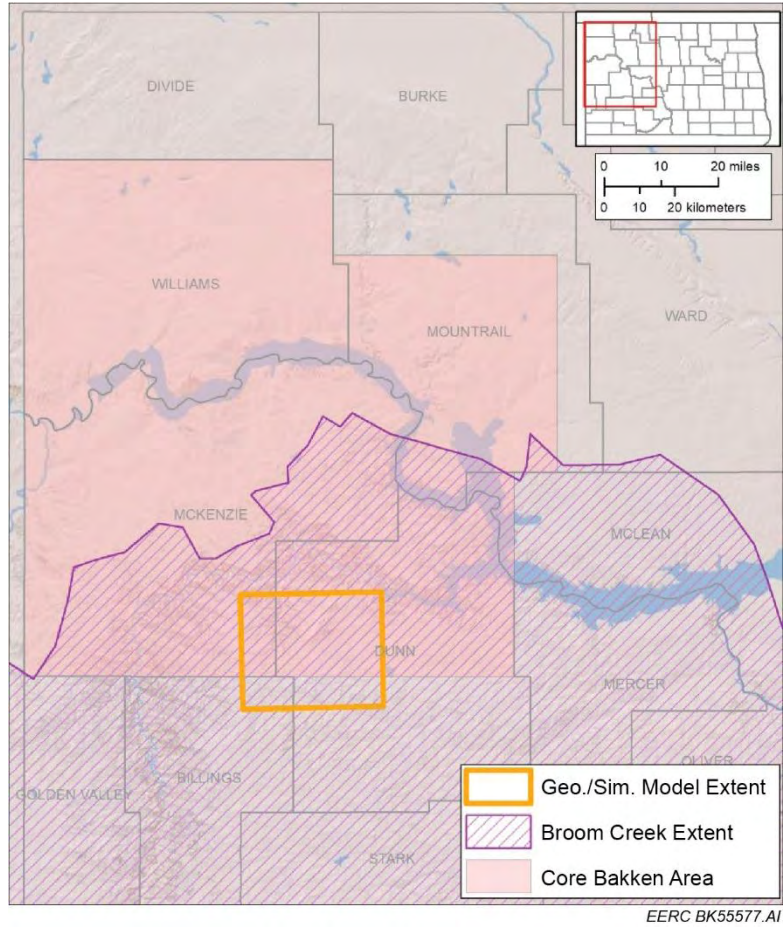

Figure A-1. Map showing the location of the geologic and simulation model.

Data

The geologic model was built using industry-standard software, Schlumberger's Petrel E&P software platform (Schlumberger, 2016). Publicly available data were used, along with data acquired from two ongoing EERC projects sponsored by the U.S. Department of Energy (DOE) National Energy Technology Laboratory (NETL): 1) "North Dakota Integrated Carbon Storage Feasibility Study," under the DOE NETL Carbon Storage Assurance Facility Enterprise (CarbonSAFE) initiative (referred to hereafter as the ND CarbonSAFE Project) and 2) "Developing and Validating Pressure Management and Plume Control Strategies in the Williston Basin Through a Brine Extraction and Storage Test (BEST) – Phase II." Publicly available data were acquired primarily from North Dakota Industrial Commission (NDIC) databases. These data included well logs, formation top depths, well datum values (i.e. Kelly bushing [KB]), and core sample descriptions and analyses. Geologic information from Rygh (1990) was also used to construct this model.

Structural Model

The structural framework of the geologic model was constructed using Broom Creek and Amsden Formation top depths from well penetrations. These measurements represented the top and base of the Broom Creek Formation. The Broom Creek within the modeled area has an average measured depth of 7750 feet and an average thickness of 164 feet (Figure A-2).

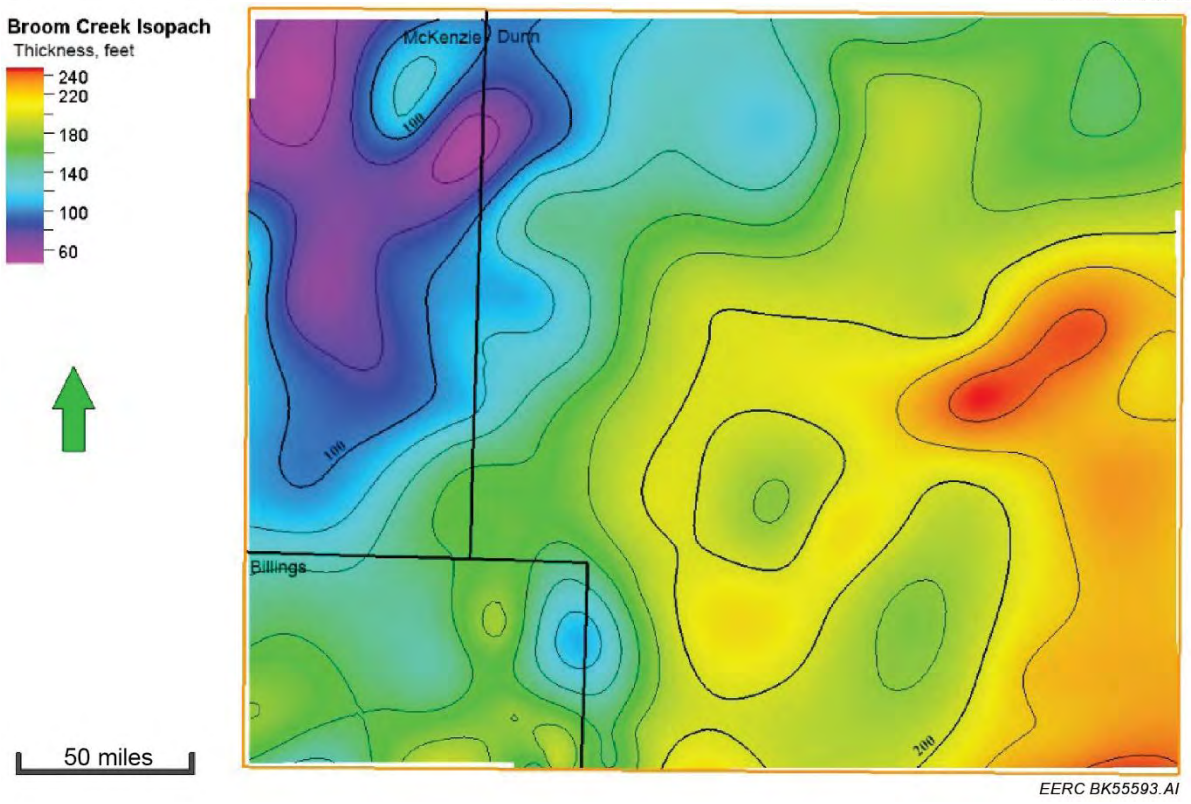
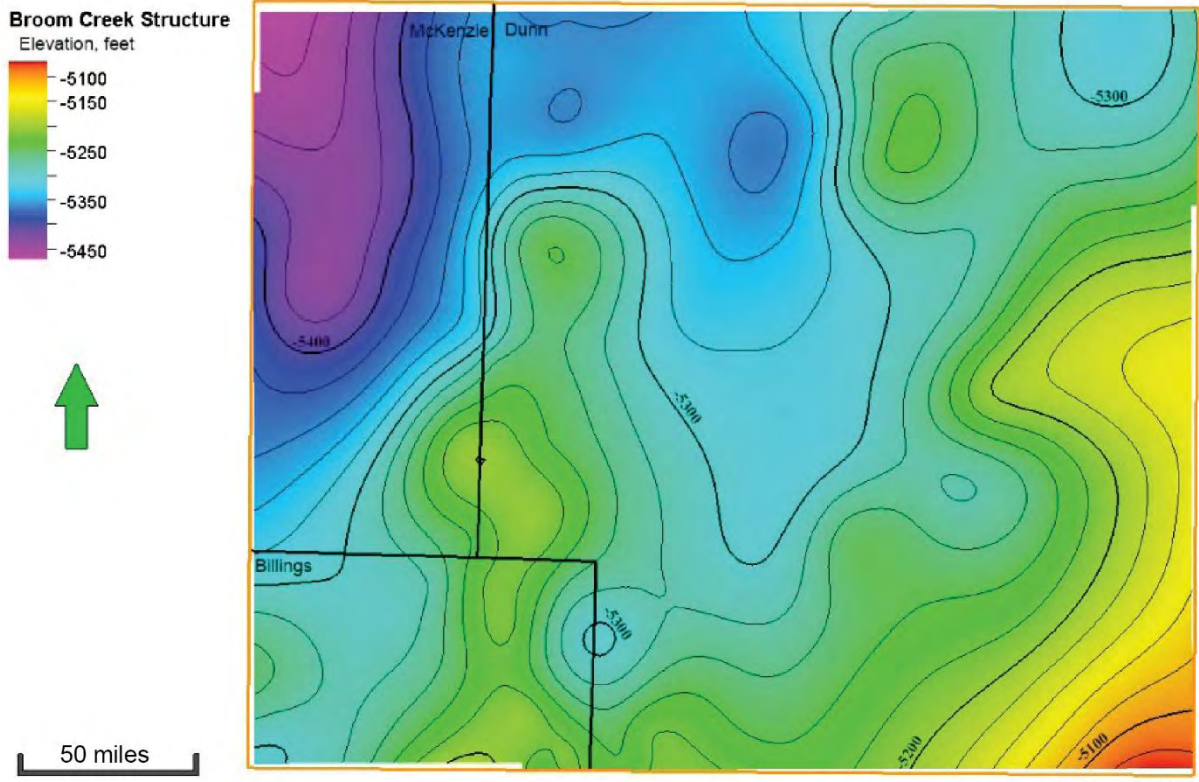

Figure A-2. Maps of the Broom Creek Formation within the modeled area. Top: Broom Creek Formation structure contour (datum is mean sea level, contour interval = 20 ft), bottom: Broom Creek Formation isopach (contour interval = 20 ft).

Lithofacies

Knowledge gained from interpretation of a 3-D seismic survey, conducted as part of the North Dakota CarbonSAFE Project, was used to inform property distributions in the model. This seismic survey was acquired approximately 50 miles east of the model location for this study. No available information (e.g., interpretation of well logs) indicated significant differences in geologic properties between the sites. Therefore, in the absence of site-specific information, an assumption was made that the Broom Creek Formation at both sites may exhibit similar architecture. General rock characteristics and statistics assessed from this survey were useful in filling knowledge gaps for the area of interest.

The analyzed seismic survey provided information regarding general orientation and relative size of geobodies within the Broom Creek Formation, defined here as rock bodies distinguishable on the basis of lithology and associated petrophysical properties. Identified geobodies included elongate eolian sand dunes, oriented generally southwest to northeast, and elongate ovular interdune carbonate beds (Figure A-3).

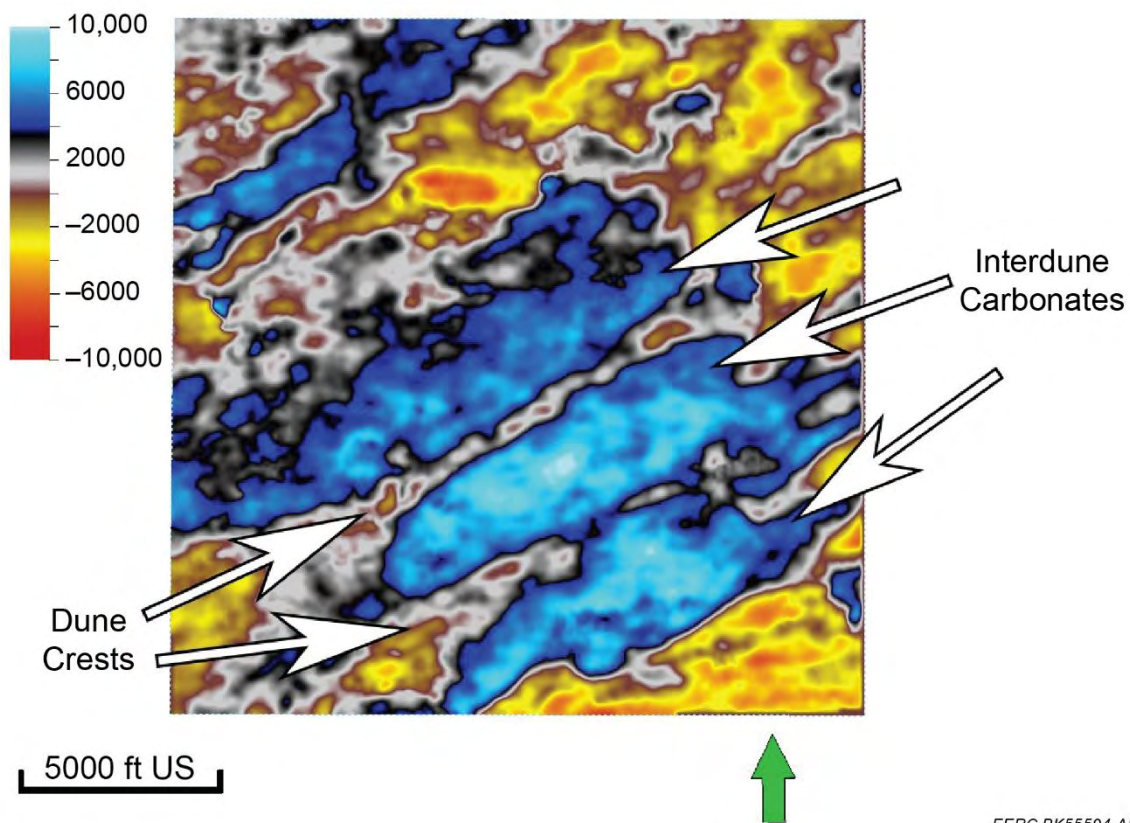

Figure A-3. Seismic amplitude time slice through the Broom Creek Formation with interpreted geobodies. Elongate eolian sand dunes (grey/yellow) are oriented approximately SW–NE. Elongate ovular carbonate deposits (blue) are present in interdune regions.

A lithofacies distribution was achieved by leveraging learnings from interpretation of the 3-D seismic survey, core sample descriptions, and well log data (Figure A-4). Lithofacies components included sandstone (51%), dolomitic sandstone (12%), dolostone (34%), and anhydrite (3%). Sandstone and dolomitic sandstone represent the most porous and permeable components of the Broom Creek Formation.

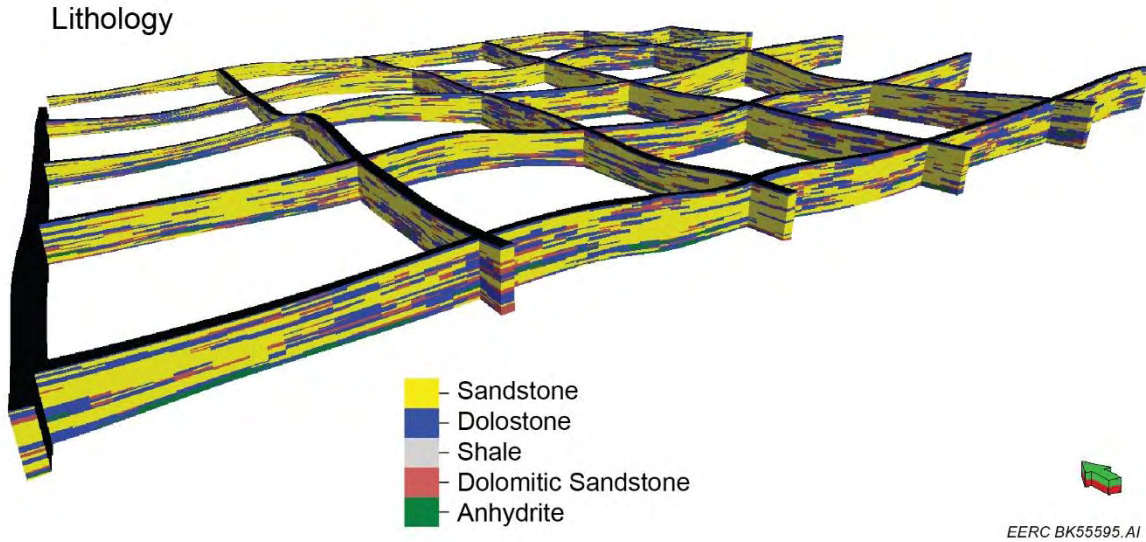

Figure A-4. Fence diagram of the Broom Creek lithofacies distribution.

Petrophysics

Petrophysical property distributions (porosity and permeability) were achieved with conditioning to the previously developed lithofacies distribution, guided by statistics derived from core sample analyses and well log data. Porosity was distributed first using a variogram-based geostatistical method, and permeability was distributed secondarily using bivariate relationships measured from the available coincidental porosity and permeability data generated in previous core analyses (Figure A-5). Porosity and permeability ranges for each Broom Creek lithofacies within the model are shown in Table A-1.

Table A-1. Porosity and Permeability Ranges for Modeled Broom Creek Lithofacies

Lithofacies	Porosity Range (mean), %	Permeability Range (mean), mD
Sandstone	2–45 (25)	0.002–7455 (479)
Dolomitic Sandstone	1–30 (12)	0.0001–1752 (27)
Dolostone	0.1–27 (7)	0.0001–100 (2)
Anhydrite	0.1–10 (2)	0.0001–2 (0.004)

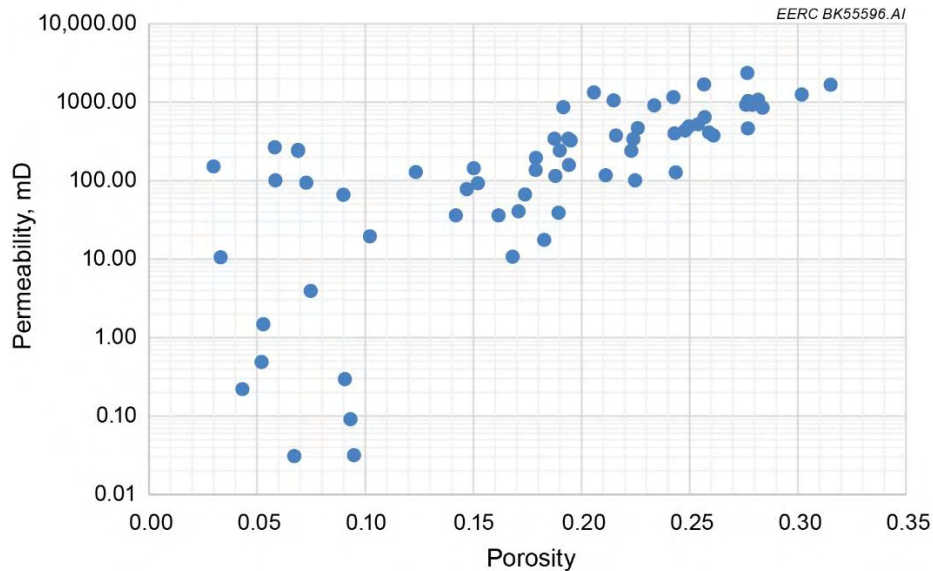

Figure A-5. Broom Creek Formation porosity–permeability crossplot.

Temperature and Pressure

Temperature and pressure property distributions were achieved using calculated gradients from two stratigraphic test wells drilled as part of the North Dakota CarbonSAFE Project (Flemmer-1 NDIC# 34243 and BNI-1 NDIC# 34244). A temperature gradient of 0.016 with a surface temperature of 43°F was derived for the Broom Creek Formation, creating a modeled temperature range of 160° to 182°F. A pressure gradient of 0.488 psi/ft for the Broom Creek calculated a modeled pressure range of 3543 psi to 4260 psi.

RESERVOIR MODEL DEVELOPMENT AND NUMERICAL SIMULATION

The geologic model was imported into CMG’s GEM software, which was used to conduct numerical simulations of gas injection and production. The simulation model extends approximately 25 mi wide (west to east) and 20 mi in length from north to south. The total number of cells in the model is just over 600,000 – 129 in the x-direction, 104 in the y-direction and 45 in the z-direction.

The simulation model was designed with open-boundary conditions, allowing lateral water flux and pressure dispersion through simulated boundary aquifers. Other settings specified within the model included fluid saturations, brine salinity, and brine–hydrocarbon gas relative permeability. Because the Broom Creek Formation contains no hydrocarbons, initial oil and hydrocarbon gas saturations were set at 0% (initial water saturation = 100%). Initial brine salinity was set at 100,000 mg/L total dissolved solids (TDS). The relative permeability assumed in the simulation was derived from literature that discusses gas flow in high-permeability saline sandstone formations (Bennion and Bachu, 2005; Figure A-6). Different sets of permeability curves generated with correlation for water-wet, well-consolidated sandstones were evaluated as well to investigate the impact on final gas recovery factor and rate.

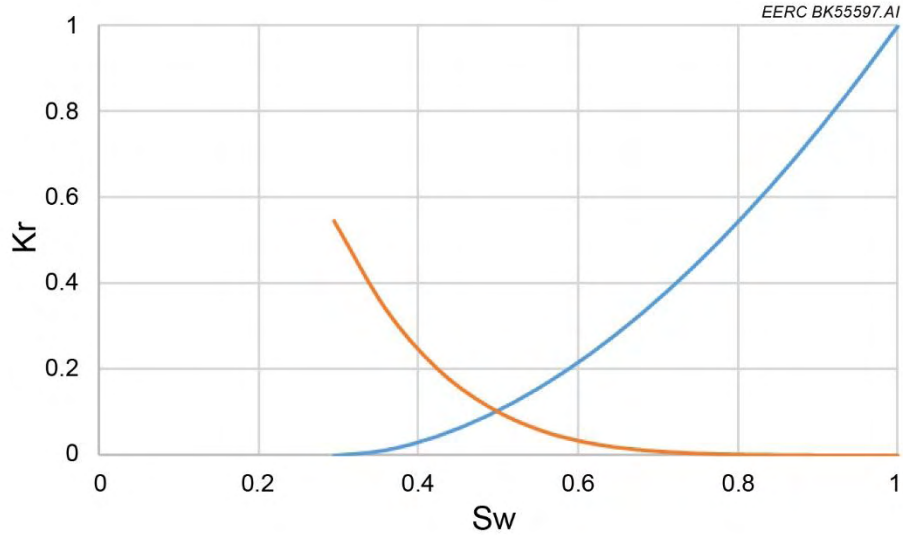

Figure A-6. Brine–gas relative permeability curves used in numerical simulation (Bennion and Bachu, 2005).

Injection and production well constraints were specified during initiation of the simulation model. The injected gas composition settings were that of typical Bakken produced gas composition. The injected gas had an assumed composition of 2.8 mol% N₂, 0.795 mol% CO₂, 0.005 mol% H₂S, 58.7 mol% C₁, 21.6 mol% C₂, 12.1 mol% C₃, and 4 mol% iC₄-nC₄. Maximum injection pressure constraints were specified to limit simulation of scenarios that may result in fracture initiation in the injection zone and/or sealing formations. Two injection well locations were selected (Figure A-7).

Well 1 was located on a structural high where injected gas would be trapped by subtle closure. Well 2 was located on the flank of a structural high. Structure was thought to be an important variable in simulation investigations, as gas tends to accumulate at the top of permeable intervals because of the effects of gravity segregation (buoyancy). Wellbore models were implemented to calculate injection wellhead pressure (WHP) response to injection rate, which is a common constraint for injection well permitting. Both wells were perforated in all of the sandstone intervals penetrated by the wellbore. No perforations were set in low-permeability rock.

In all of the simulation runs, it was assumed that the gas (and formation brine) would be produced by excess reservoir pressure. No artificial lift mechanisms were evaluated within the simulation cases.

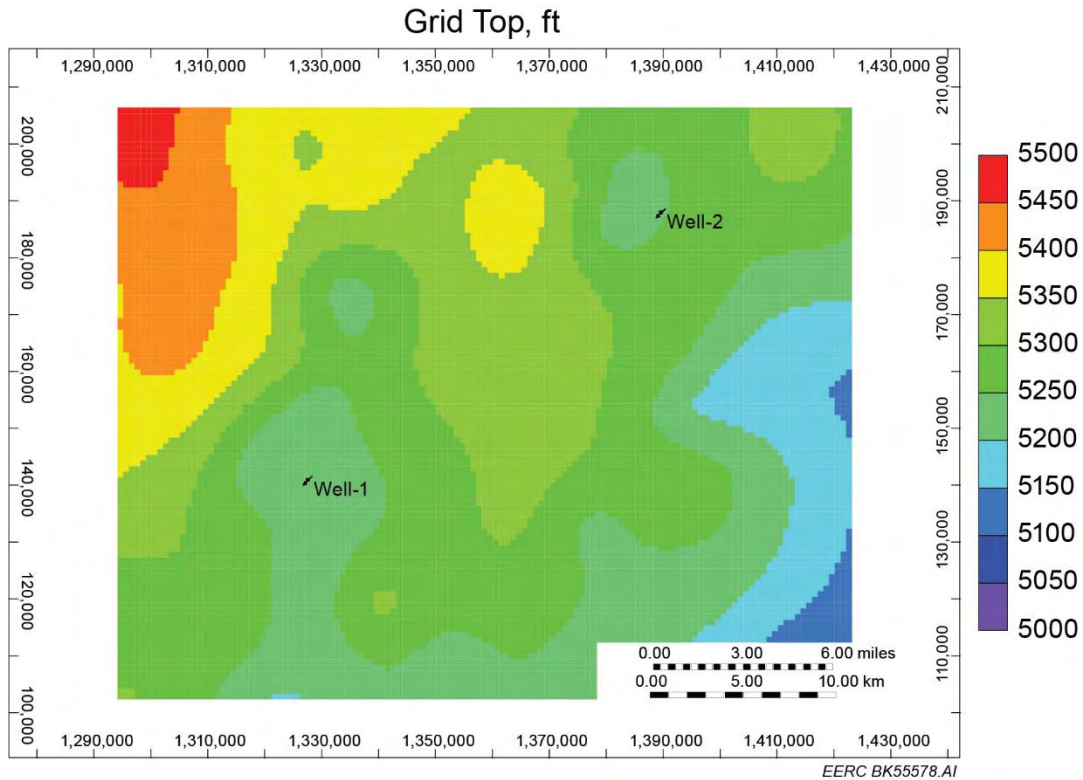

Figure A-7. 3-D view of the simulation model showing injection well locations and depth of the Broom Creek Formation top (in feet).

A preliminary simulation scenario (Case 1) was set up, with constraints for both wells including 10 MMscf/day injection for 6 months and well shut-in for 5 years, followed by gas production for 5 years. No producing bottomhole pressure (BHP) or rate constraints were applied, and minimum WHP constraint of 15 psi was applied. This setting would allow the reservoir to produce at the maximum possible rate.

The resulting simulated recovery factors for both wells are shown in Figure A-8. Simulated gas and water production rates for both wells in Case 1 are shown in Figure A-9.

The figures above show recovery factors would be 16% to 27% without constraining pressure and water/gas production rate. The fast depletion process caused higher instantaneous water and gas production that caused a sudden pressure drop in WHP, resulting in a loss of production. The cyclic nature of production from this simulation case resulted in low recovery factor and high water production. In practice, producing BHP and water rate should be constrained in order to maintain a steady production over time.

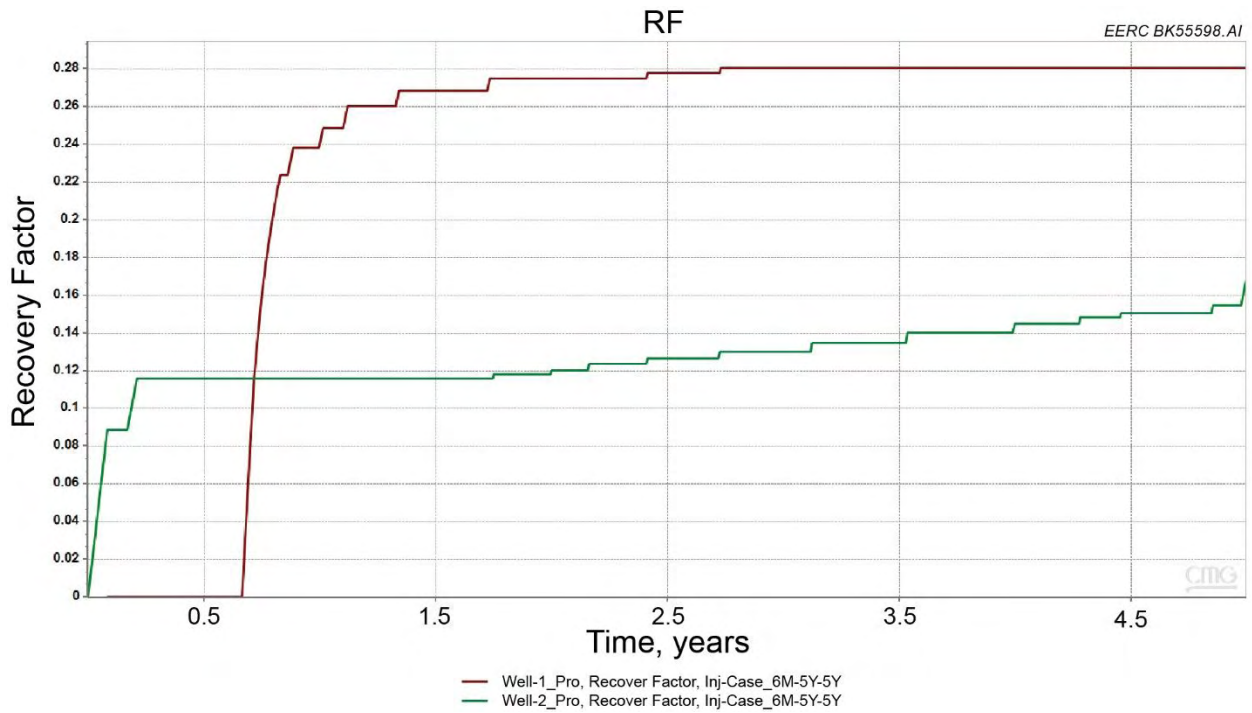

Figure A-8. Recovery factors for both wells in Case 1: 10 MMscf/day injection for 6 months, 5-years shut-in, and 5-year production.

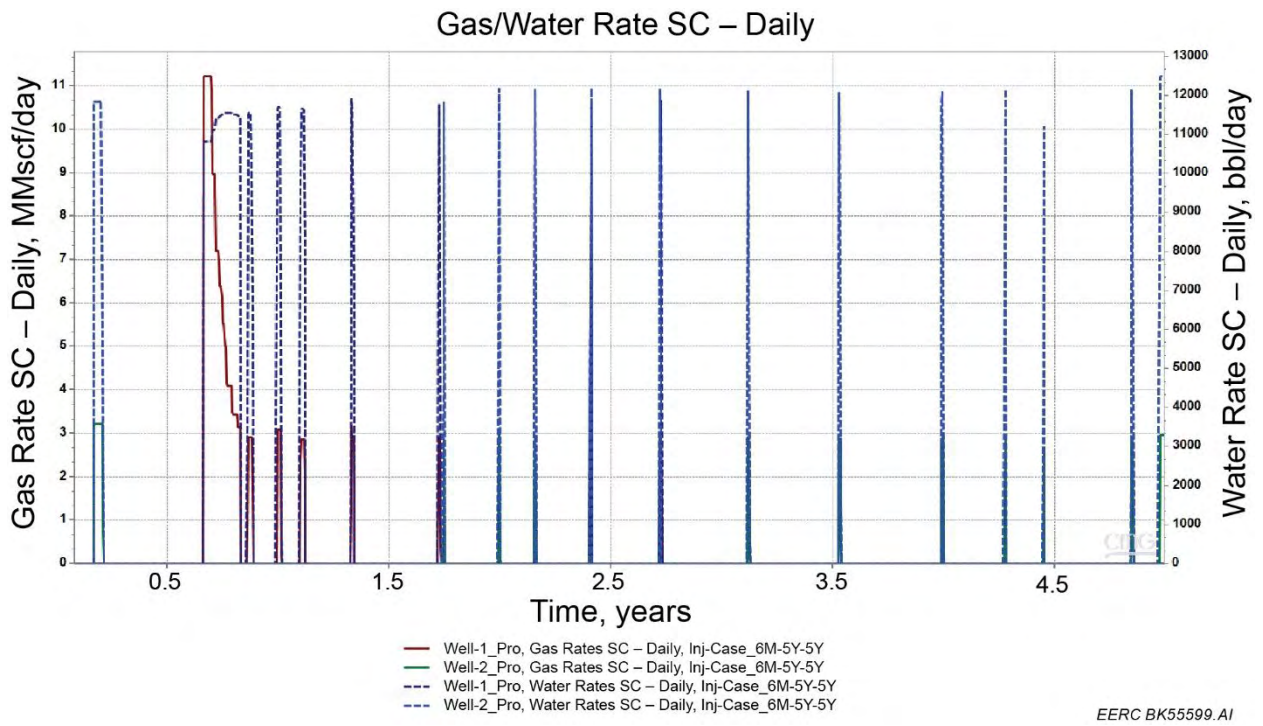

Figure A-9. Gas and water production rate for Case 1: 10 MMscf/day injection for 6 months, 5-years shut-in, and 5-year production.

Several additional simulation scenarios were developed, as summarized in Table A-2. Injection rates included 10 and 30 MMscf/day. In those cases, production BHP was set at 3500 psi, which is close to initial reservoir pressure (prior to gas injection), and maximum water production rate was set at 10,000 bbl/day, which is a rate that may be achieved by a dedicated saltwater disposal (SWD) well in the Inyan Kara Formation (produced water disposal target in Williston Basin). Production scenarios were tested, with a subset of cases simulating production immediately following injection (no shut-in interval) and a subset with production beginning after a 5-year shut-in interval.

Table A-2. Simulation Scenarios for 6-month Gas Injection

Case ID	Injection Rate	Injection Time	Gas Withdrawal after Injection	Gas	Gas	Gas
				Recovery Factor after 1 year of Production (Well 1; Well 2)	Recovery Factor after 2 years of Production (Well 1; Well 2)	Recovery Factor after 5 years of Production (Well 1; Well 2)
2	10 MMscf/day	6 months	Immediate	53%; 44%	63%; 52%	74%; 64%
3			5 years	44%; 26%	51%; 35%	61%; 49%
4	30 MMscf/day	6 months	Immediate	51%; 40%	59%; 45%	68%; 54%
5			5 years	42%; 28%	49%; 33%	57%; 42%

The predicted gas recovery factors for each scenario after 1, 2, and 5 years of production are given in Table A-2. Figure A5 depicts the gas recovery factors for each scenario over a 5-year production period. The simulation results showed greater gas recovery was obtained when production immediately followed injection, rather than shutting in the well for 5 years. Well 1 performed better than Well 2, which is likely because the location and structure limited lateral gas migration and improved containment, resulting in improved gas recovery.

Table A-3 summarizes the predicted daily water and gas production rates after 6 months, 1 year, 2 years, and 5 years of gas production. Plots depicting this information as well as gas:water ratios are shown in Figures A-10 and A-11. The higher gas injection rate (30 MMscf/day) resulted in higher peak gas production; however, the recovery factor after 5 years was less than the lower injection rate case (10 MMscf/day). It is worth noting that during the production period for each case, a relatively high gas production rate occurred for about 1 year, after which both simulated gas rate and gas/water ratio dropped to very low levels (Table A-3, Figure A-11).

Table A-3. Simulated Gas and Water Production Rates after 6 months, 1 year, 2 years, and 5 years of Gas Production for Cases 2–5 (6-month injection period)

Case ID	Injection Rate	Gas Withdrawal after Injection	Production Rates after 6 months		Production Rates after 1 year		Production Rates after 2 years		Production Rates after 5 years	
			Daily Gas Rate, MMscf/day (Well 1; Well 2)	Daily Water Rate, bbl/day (Well 1; Well 2)	Daily Gas Rate, MMscf/day (Well 1; Well 2)	Daily Water Rate, bbl/day (Well 1; Well 2)	Daily Gas Rate, MMscf/day (Well 1; Well 2)	Daily Water Rate, bbl/day (Well 1; Well 2)	Daily Gas Rate, MMscf/day (Well 1; Well 2)	Daily Water Rate, bbl/day (Well 1; Well 2)
2	10	Immediate	1.7; 1.3	10,000; 10,000	0.8; 0.7	10,000; 9469	0.3; 0.3	9876; 9467	0.1; 0.1	8903; 8555
3	MMscf/day	5 years	1.3; 0.9	9371; 9370	0.5; 0.5	9590; 9001	0.3; 0.3	9209; 8582	0.1; 0.1	8533; 8087
4	30	Immediate	4.7; 2.6	9139; 9957	2.0; 1.2	9671; 8949	1.1; 0.7	9675; 8953	0.3; 0.3	8616; 8128
5	MMscf/day	5 years	4.2; 2.5	8475; 8194	1.5; 1.3	8932; 8253	0.7; 0.6	8796; 8129	0.3; 0.3	8266; 7720

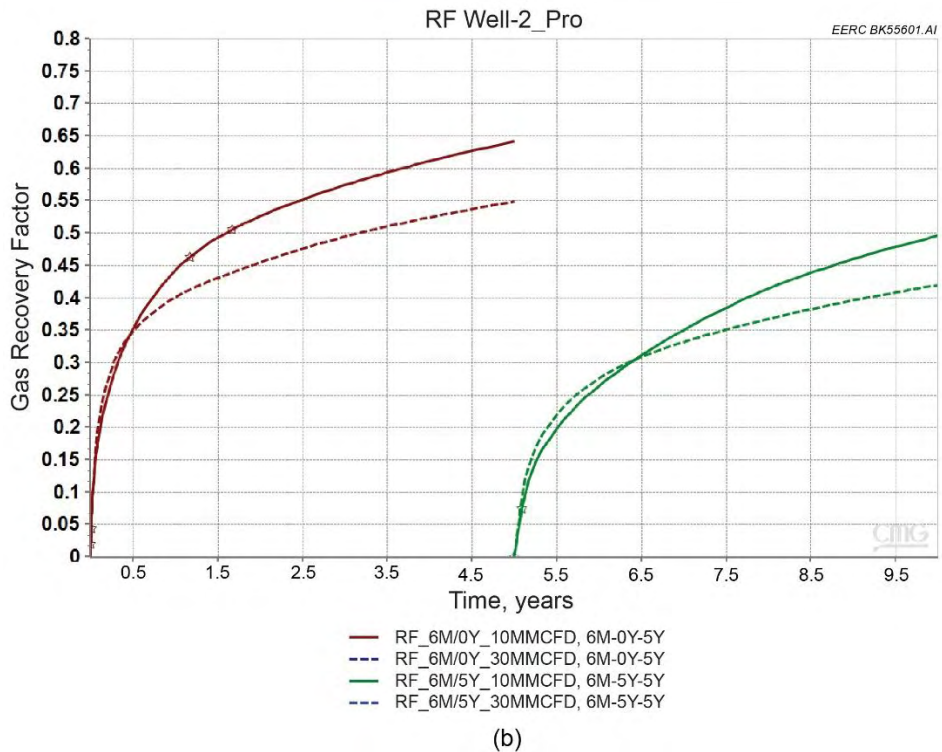
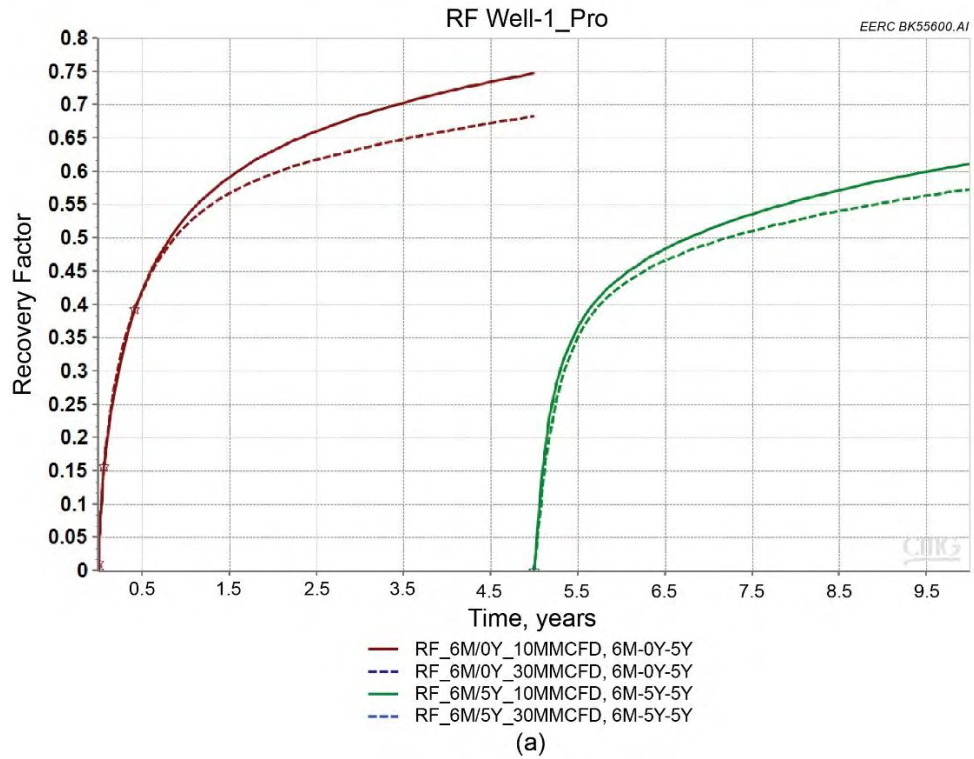
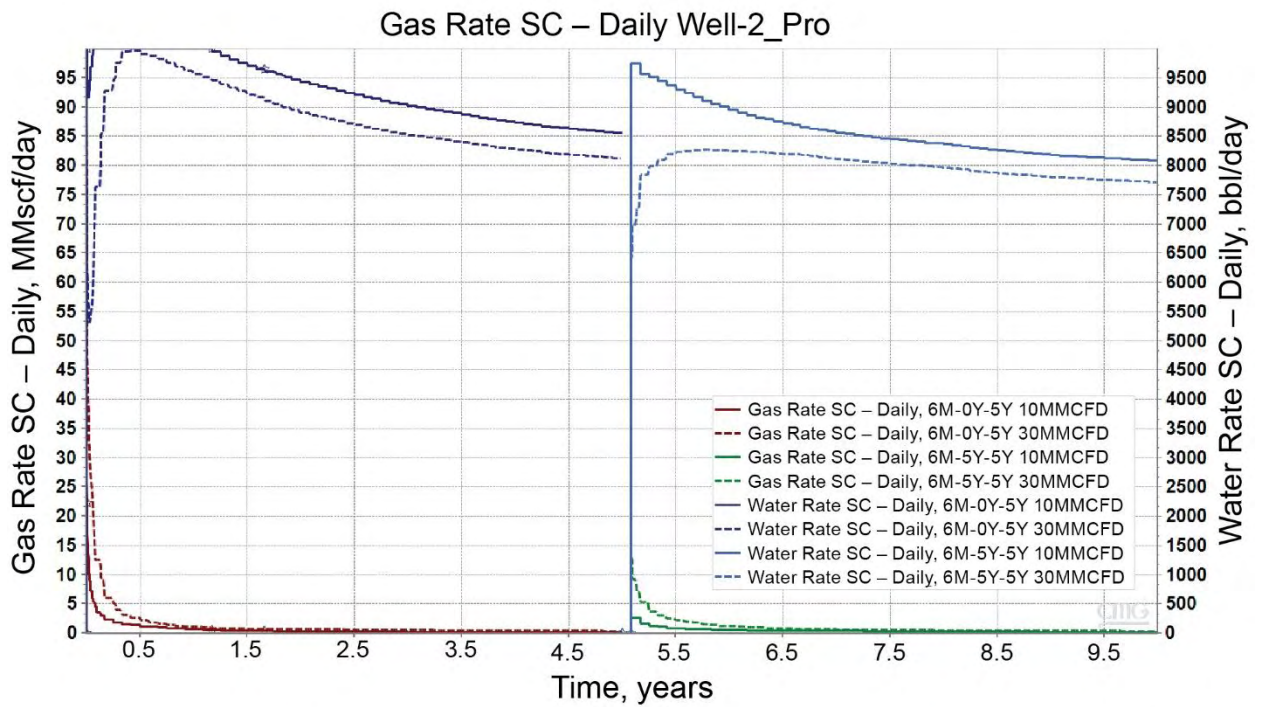
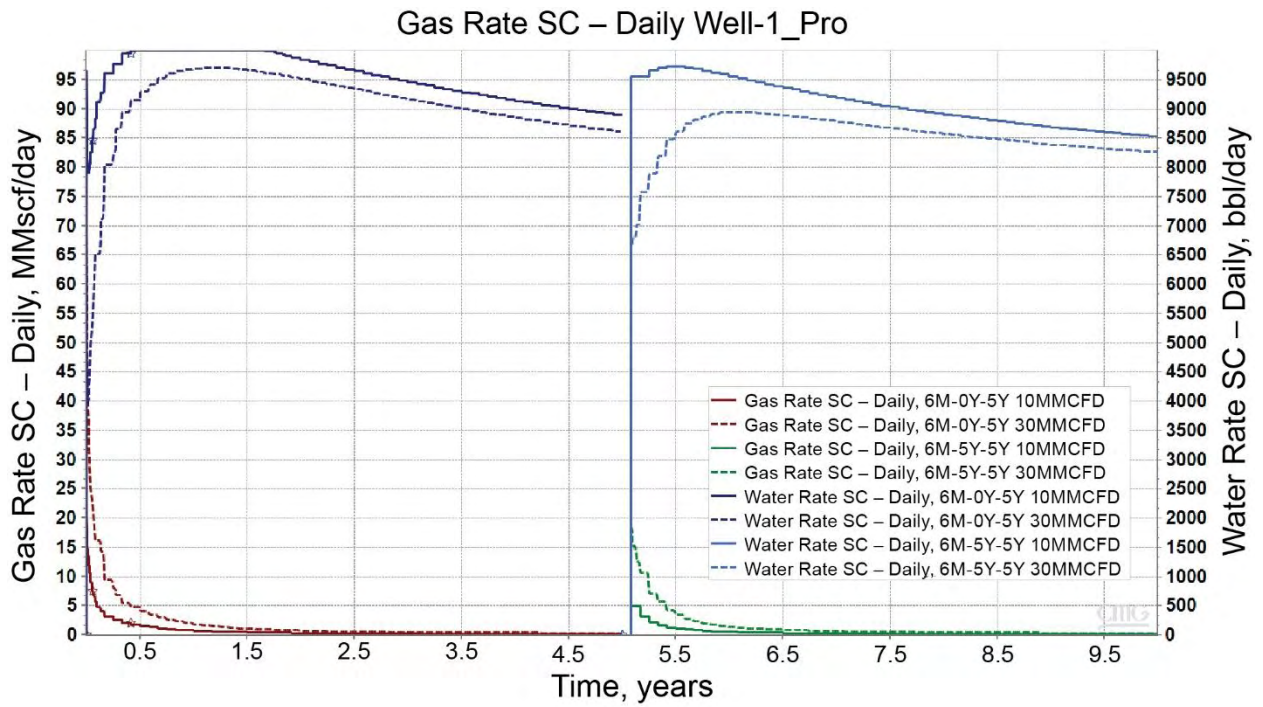

Figure A-10. Well 1 (a) and Well 2 (b) simulated gas recovery factor for 6-month injection, Cases 2-5.



EERC BK55602.AI

Figure A-11. Well 1 (a) and Well 2 (b) simulated gas/water rate for 6-month injection, Cases 2–5.

Figure A-12 shows the simulated gas plume for Well 1 after 6 months of injection at a rate of 10 MMscf/day. It is interesting to note that the plume extent is shown in gas per unit area, which is a measurement that considers the saturation, porosity, and pay thickness of each cell. Because there are 45 vertical layers in the model, to illustrate the aerial plume extent, each layer's gas per unit area was summarized for all layers beneath each cell. Because of the relatively low total injection volume, the gas plume remained in the near-wellbore area (approximately 3000 feet maximum diameter). Both wells showed similar plume development.

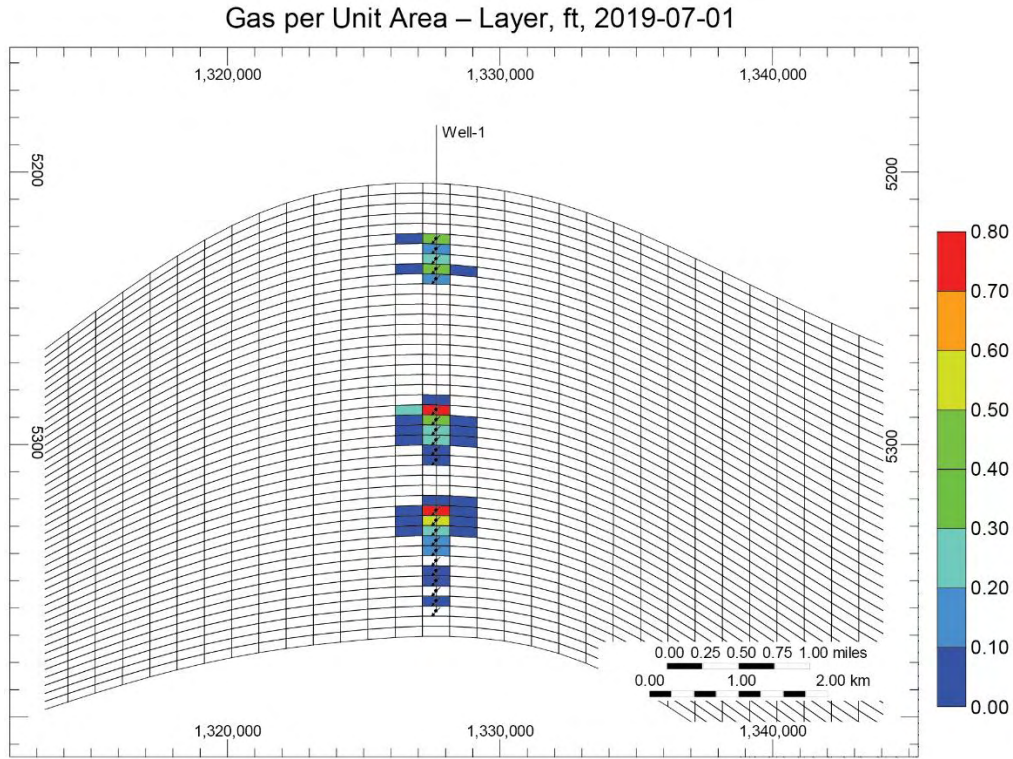

(a)

EERC BK55603.AI

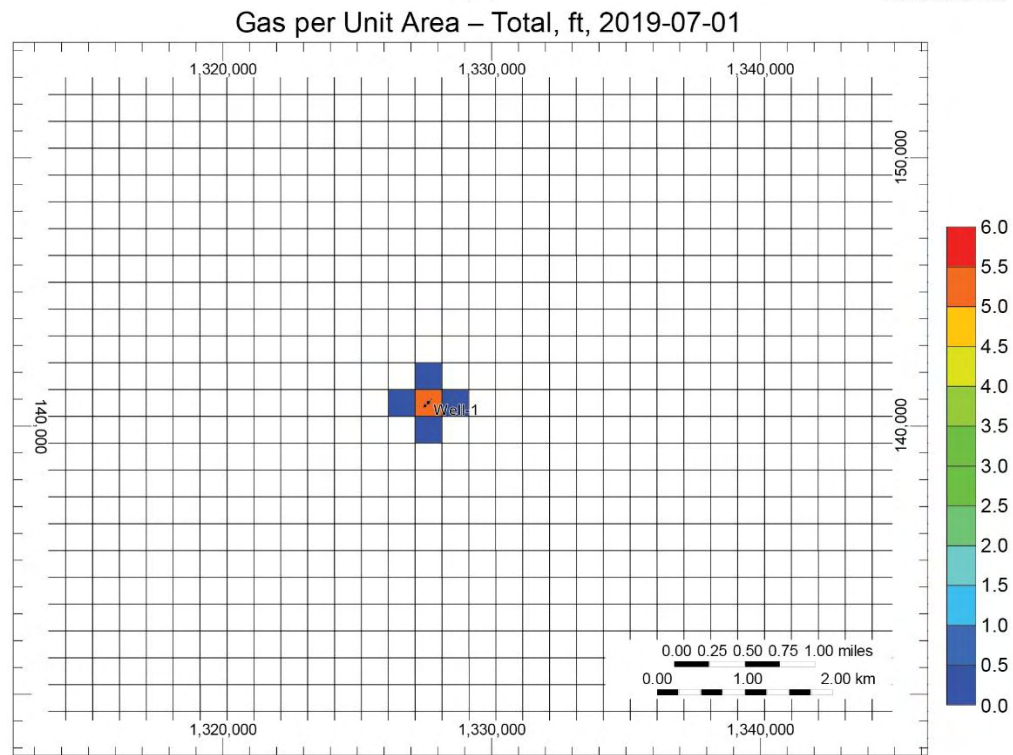

(b)

EERC BK55604.AI

Figure A-12. Cross-sectional view (a) and aerial view (b) of the simulated gas plume after 6 months of injection. The vertical exaggeration in image “a” is 75x.

Six months of gas injection may not be a sufficient time period to allow for additional capacity to be created within the pipeline infrastructure to capture excess gas. Additional simulation scenarios were developed with 2-year gas injection time frames. Immediate recovery, as well as 1-, 3-, and 5-year shut-in cases were simulated to further investigate the impact of shut-in time on gas recovery. These operational scenarios are summarized in Table A-4.

Table A-4. Simulation Scenarios for 2-year Gas Injection Operations

Case ID	Injection Rate	Injection Time	Gas Withdrawal after Injection	Gas Recovery Factor after 1 year of Production (Well 1; Well 2)	Gas Recovery Factor after 2 years of Production (Well 1; Well 2)	Gas Recovery Factor after 5 years of Production (Well 1; Well 2)
6	10 MMscf/day	2 years	Immediate	49%; 37%	56%; 44%	64%; 51%
7			1 year	48%; 36%	54%; 41%	62%; 48%
8			3 years	45%; 31%	51%; 36%	57%; 43%
9			5 years	40%; 28%	46%; 33%	53%; 40%
10	30 MMscf/day	2 years	Immediate	46%; 43%	55%; 50%	63%; 57%
11			1 year	43%; 40%	53%; 47%	61%; 54%
12			3 years	40%; 36%	51%; 43%	58%; 51%
13			5 years	36%; 33%	48%; 40%	55%; 48%

Figure A-13 illustrates the recovery factors for Cases 6–9, all with the 10-MMscf/day injection rate, and Figure A-14 depicts the recovery factor for Cases 10–13, all with the 30-MMscf/day injection rate. The recovery factors for each scenario after 1, 2, and 5 years of production are also given in Table A-4. The results show that the recovery factor decreases as shut-in time increases. Immediate production following injection appears the most effective operational scenario to maximize recovery.

Table A-5 summarizes the predicted daily water and gas production rates after 6 months, 1 year, 2 years, and 5 years of gas production. Plots depicting this information are contained in Figures A-15 and A-16. Similar to the 6-month injection cases, the rate of recovery declines after 1 year of gas production. Cases with greater injection rates (30 MMscf/day versus 10 MMscf/day) resulted in greater production rates during the first few months of production. After 2 years of injection at 10 and 30 MMscf/day, the gas plume size was predicted to be 5000 and 9000 ft in diameter, respectively (Figure A-17).

It is interesting to note that while immediate recovery results in the highest overall recovery factor, the initial gas production rates (as shown in Figures A-15 and A-16) can be extremely high – over 70 MMscf/day in the 10-MMscf/day injection rate case (Well 1) and approximately 140 MMscf/day in the 30-MMscf/day injection rate case (Well 1). Initial gas production rates drop to over half of those rates if gas recovery is delayed by 1 year. To avoid overwhelming the capacity of the pipeline infrastructure, which would likely not be designed to handle such large production rates, it may help to delay gas production and/or constrain gas production rates (as described later in this text).

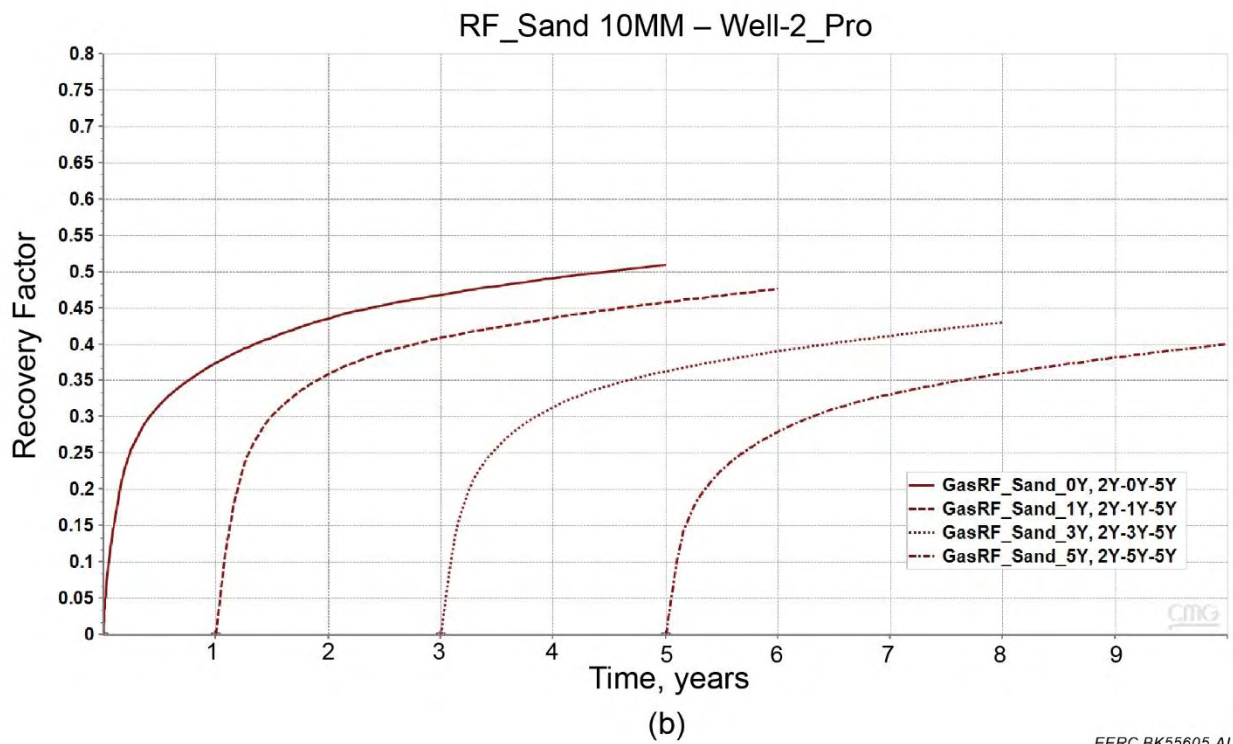
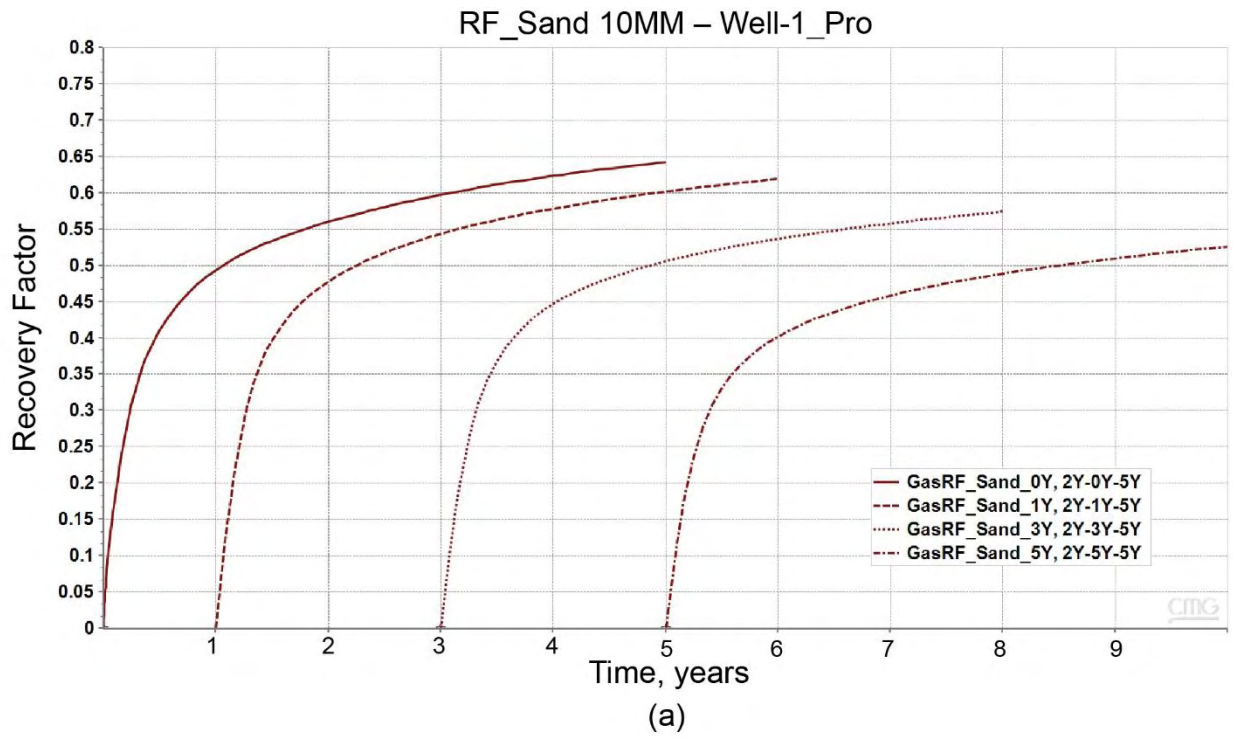

EERC BK55605.AI

Figure A-13. Well 1 (a) and Well 2 (b) gas recovery factor for 2 years of injection followed by varying shut-in periods and subsequent production, Cases 6–9, 10 MMscf/day injection.

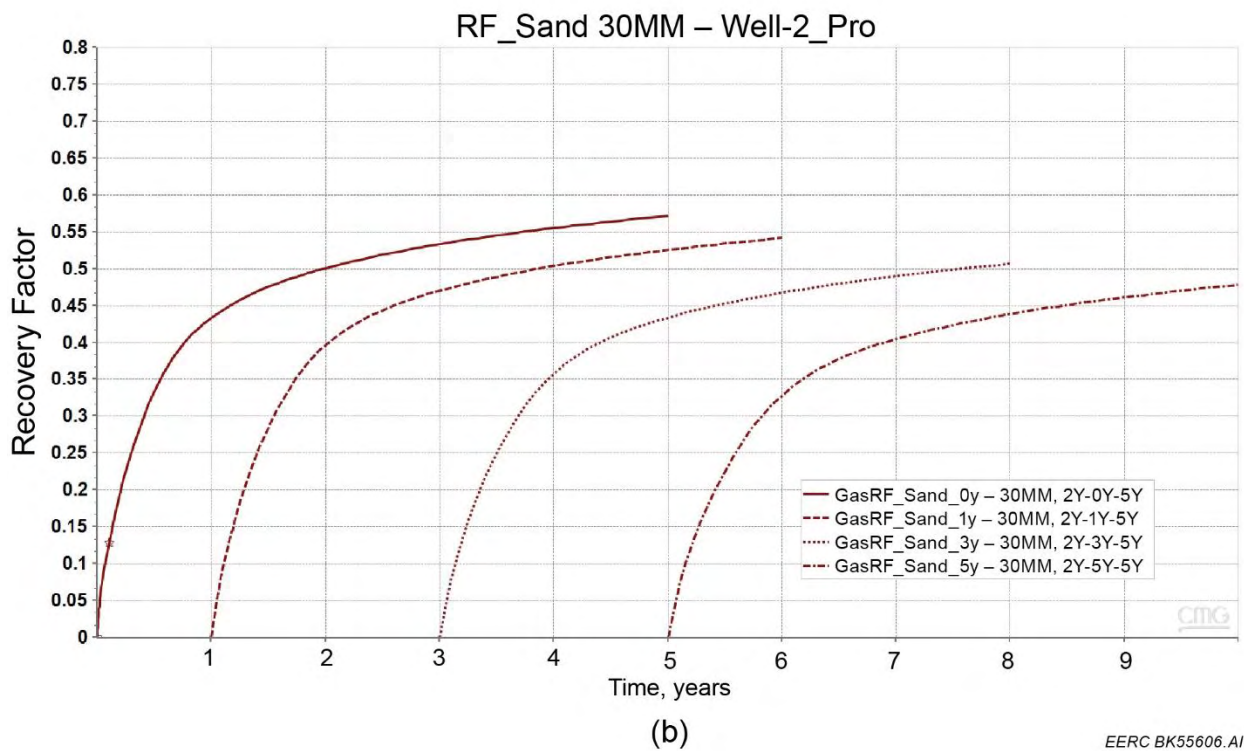
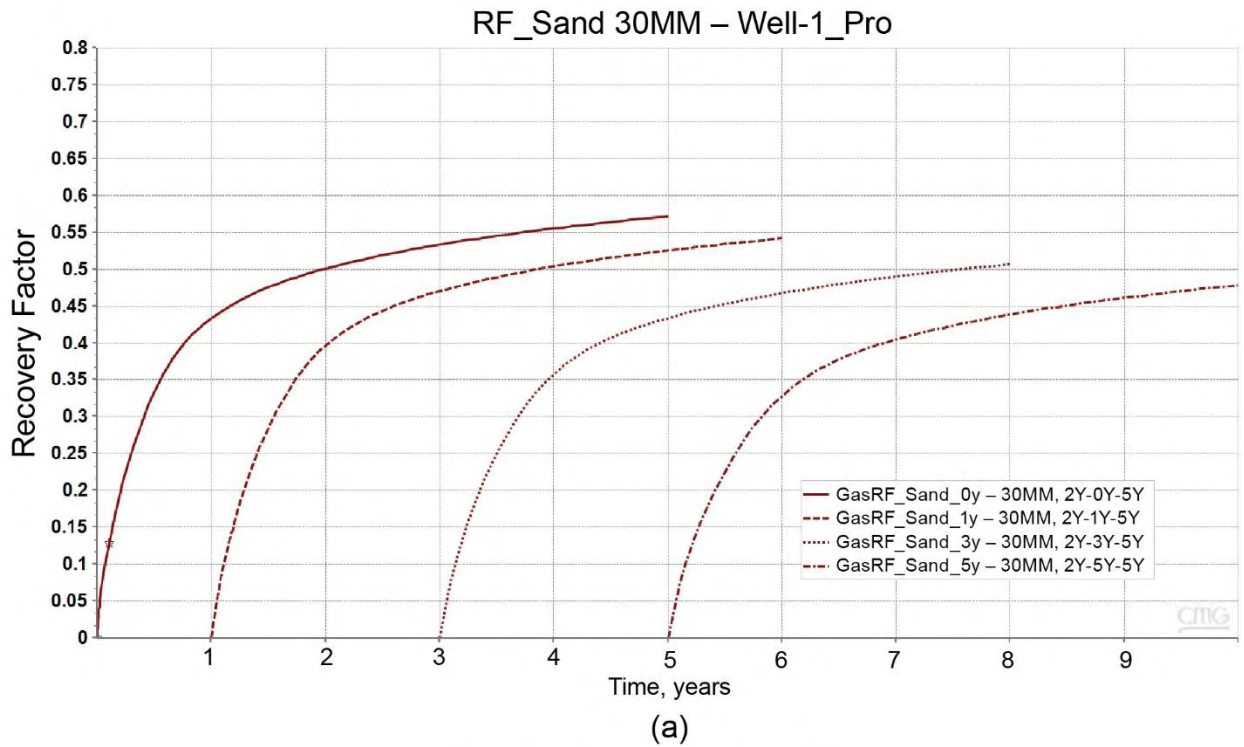

EERC BK55606.AI

Figure A-14. Well 1 (a) and Well 2 (b) gas recovery factor for 2 years of injection followed by varying shut-in periods and subsequent production, Cases 10–13, 30 MMscf/day injection.

Table A-5. Simulated Gas and Water Production Rates after 6 months, 1 year, 2 years, and 5 years of Gas Production for Cases 6–13 (2-year injection period)

Case ID	Injection Rate	Gas Withdrawal after Injection	Production Rates after 6 Months		Production Rates after 1 Year		Production Rates after 2 Years		Production Rates after 5 Years	
			Daily Gas Rate, MMscf/day (Well 1; Well 2)	Daily Water Rate, bbl/day (Well 1; Well 2)	Daily Gas Rate, MMscf/day (Well 1; Well 2)	Daily Water Rate, bbl/day (Well 1; Well 2)	Daily Gas Rate, MMscf/day (Well 1; Well 2)	Daily Water Rate, bbl/day (Well 1; Well 2)	Daily Gas Rate, MMscf/day (Well 1; Well 2)	Daily Water Rate, bbl/day (Well 1; Well 2)
6	10 MMscf/day	Immediate	5.6; 3.5	8472; 8371	2.3; 1.8	9241; 8545	1.0; 1.0	9140; 8361	0.4; 0.4	8398; 7861
7		1 year	5.7; 3.7	8027; 7816	2.2; 1.7	8962; 8281	1.0; 0.7	8927; 8243	0.4; 0.4	8320; 7785
8		3 years	5.9; 3.5	7744; 7631	2.2; 1.7	8688; 8017	0.8; 0.7	8708; 8020	0.3; 0.4	8208; 7626
9		5 years	5.1; 3.2	7866; 7643	1.9; 1.7	8598; 7912	0.8; 0.7	8600; 7901	0.3; 0.4	8135; 7532
10	30 MMscf/day	Immediate	22.2; 19.4	5190; 4250	10.7; 6.6	7164; 6756	2.8; 2.5	8562; 7425	0.9; 0.9	8082; 7258
11		1 year	21.3; 18.9	4691; 3347	10.9; 8.0	6588; 5581	2.9; 2.6	8197; 7008	0.9; 0.9	7975; 7164
12		3 years	19.7; 17.4	4494; 3361	11.2; 8.2	6052; 5195	2.9; 2.6	7760; 6667	0.9; 0.9	7812; 6956
13		5 years	18.9; 16.7	4493; 3621	10.8; 8.2	5876; 5142	3.3; 2.6	7519; 6547	0.8; 0.9	7726; 6855

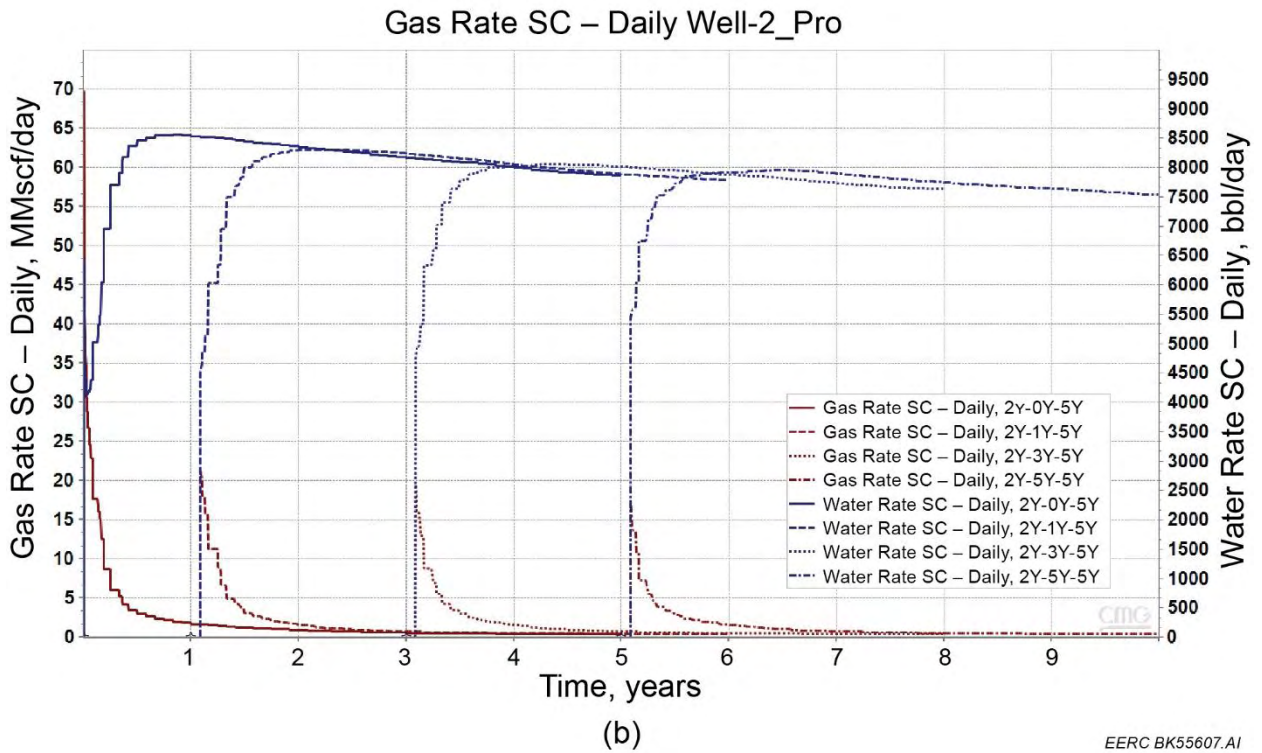
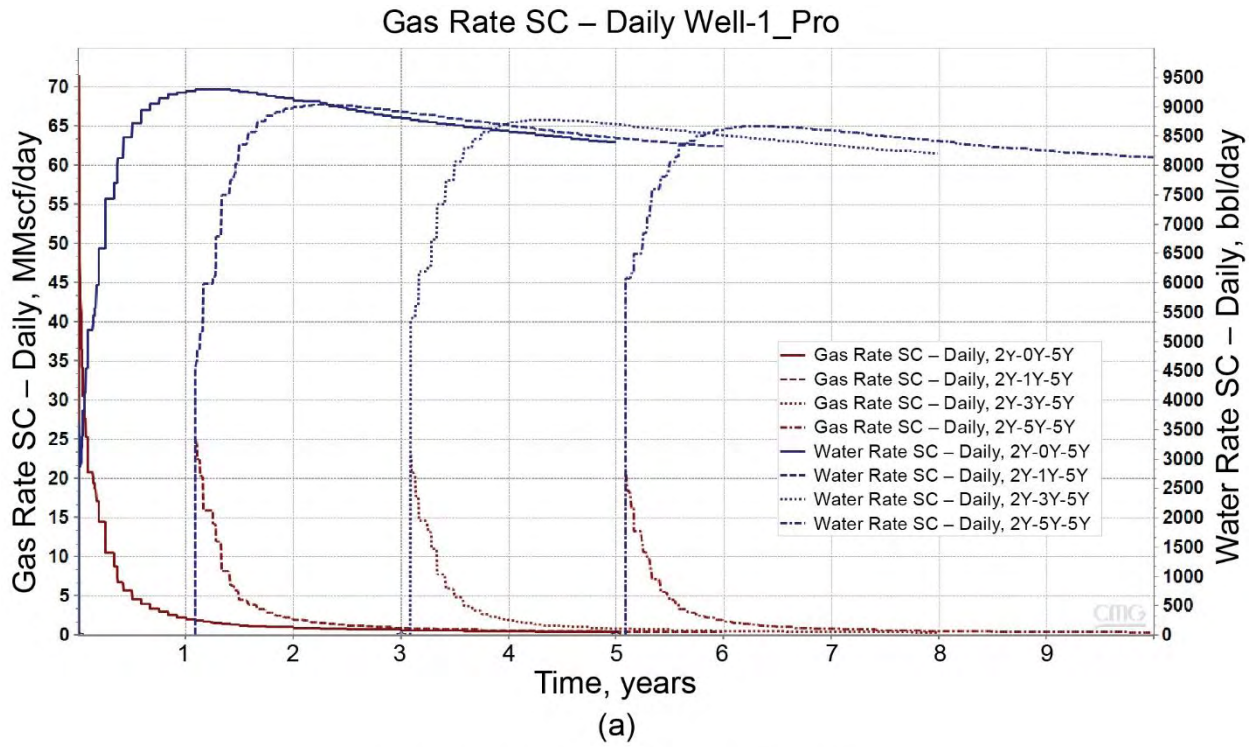
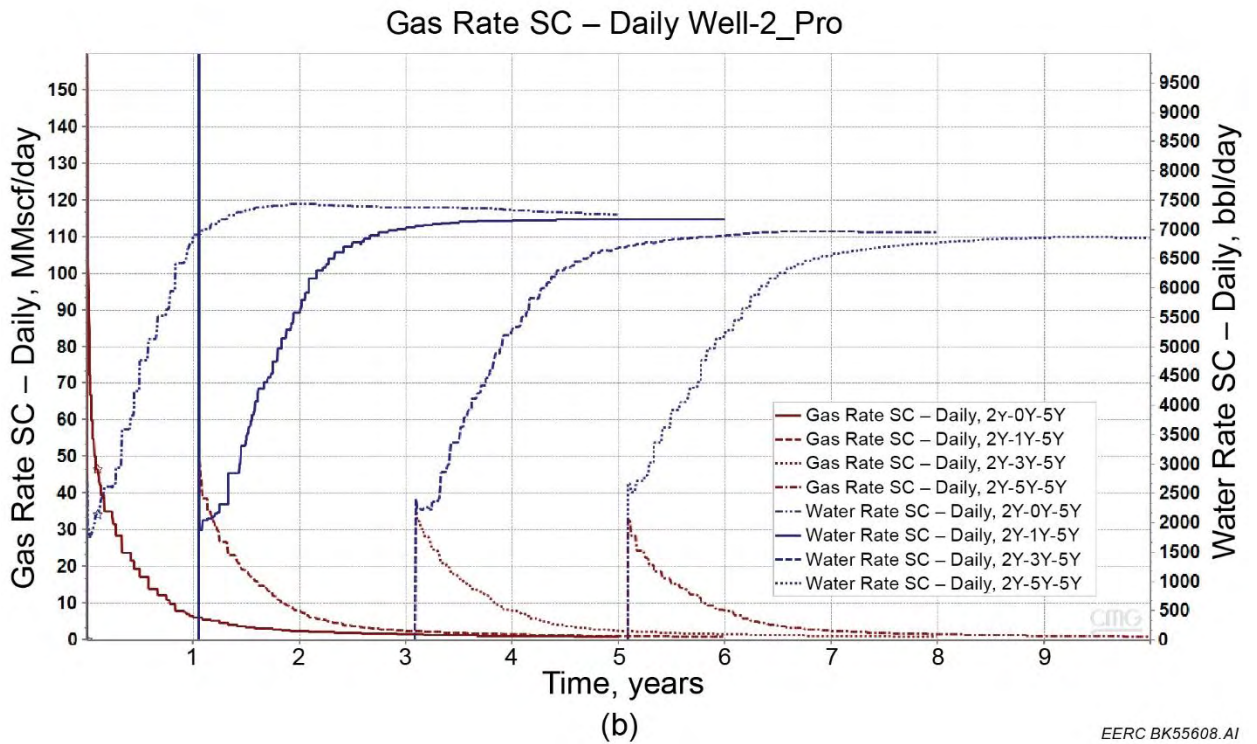
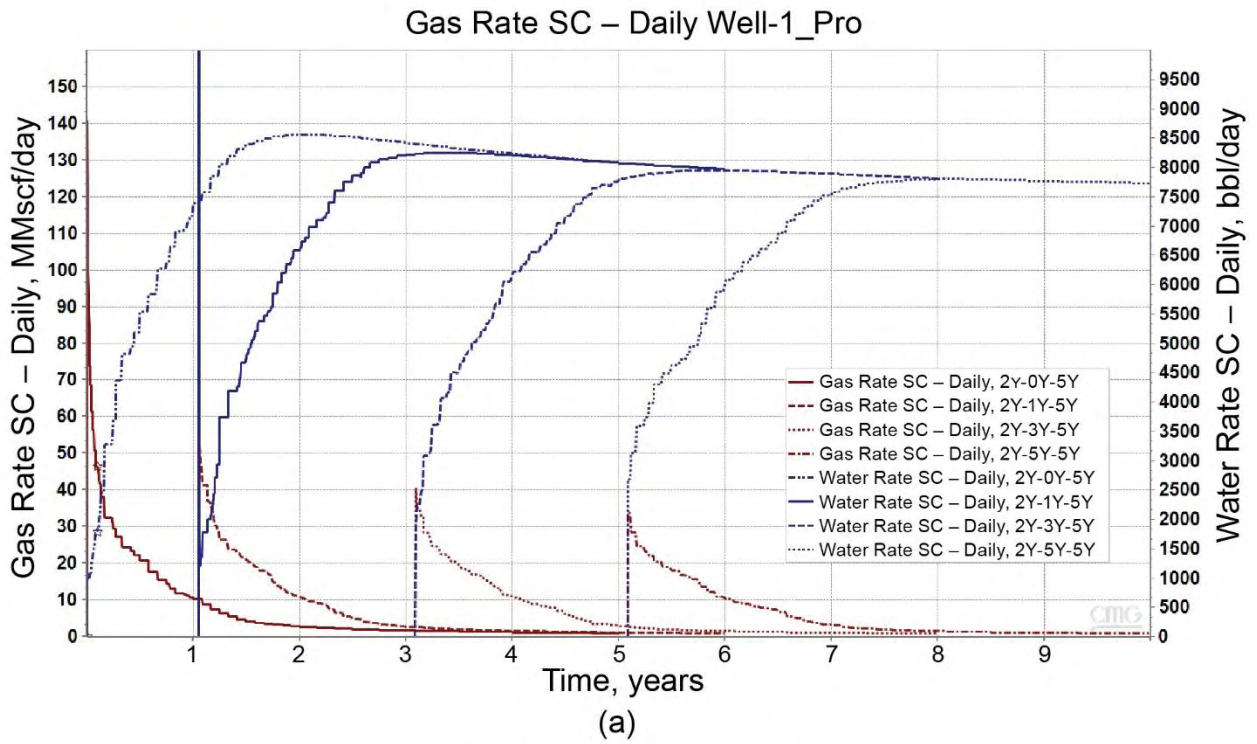
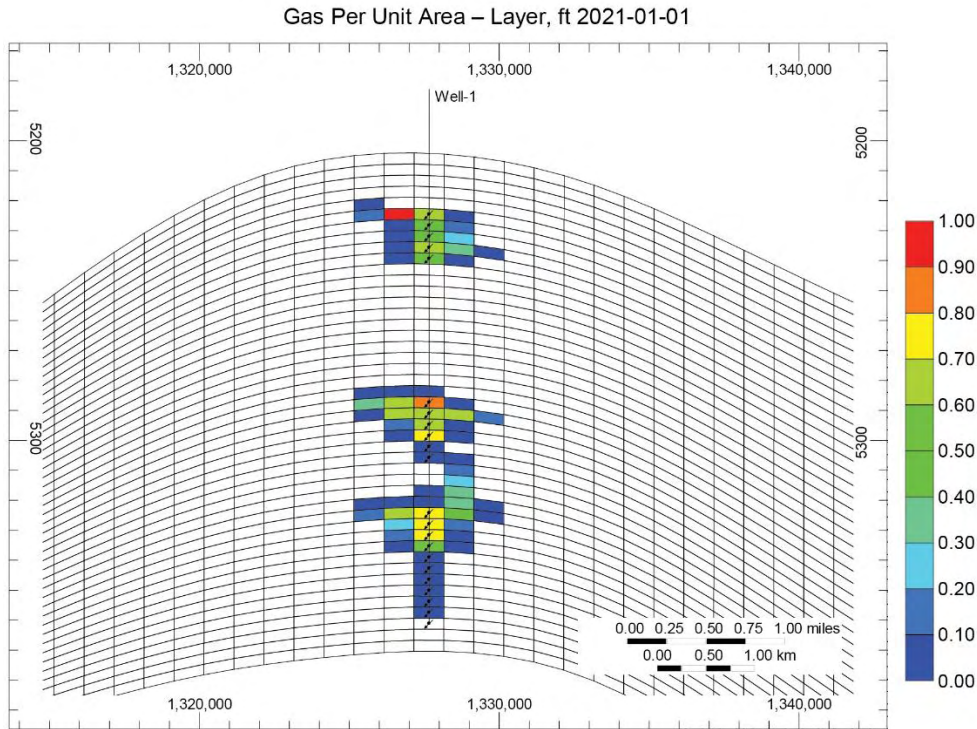

Figure A-15. Well 1 (a) and Well 2 (b) gas/water rates for 2 years of injection followed by varying shut-in periods and subsequent production, Cases 6–9, 10 MMscf/day injection.



EERC BK55608.AI

Figure A-16. Well 1 (a) and Well 2 (b) gas/water rates for 2 years of injection followed by varying shut-in periods and subsequent production, Cases 10–13, 30 MMscf/day injection.



(a)

EERC BK55609.AI

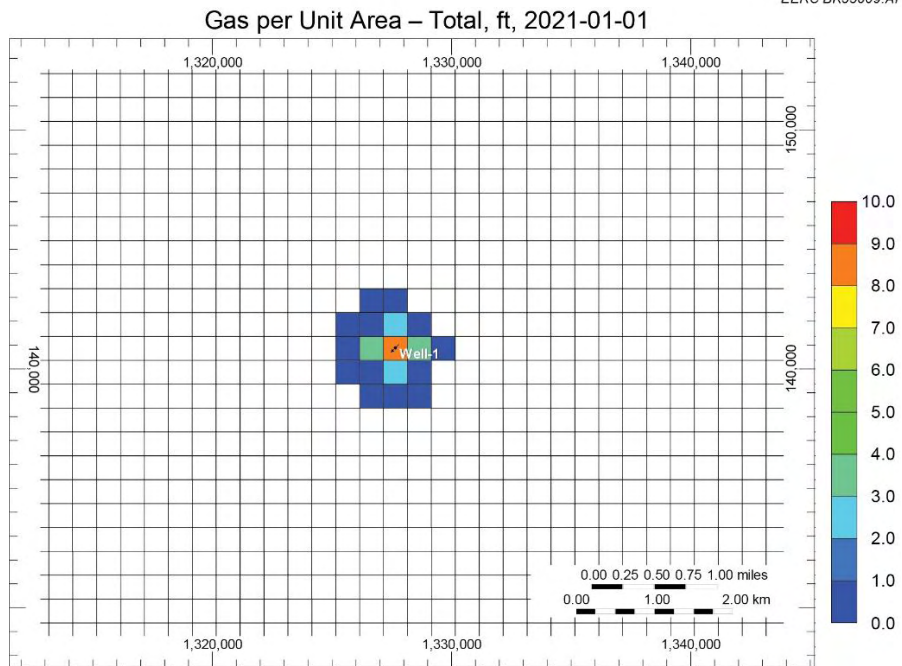

(b)

EERC BK55610.AI

Figure A-17. Cross-sectional and aerial views of the predicted gas plume extents following 2 years of injection at 10 MMscf/day (top a and b) and 30 MMscf/day (bottom c and d). The vertical exaggeration in image “a” is 75× (continued).

Gas per Unit Area – Layer, ft, 2021-01-01

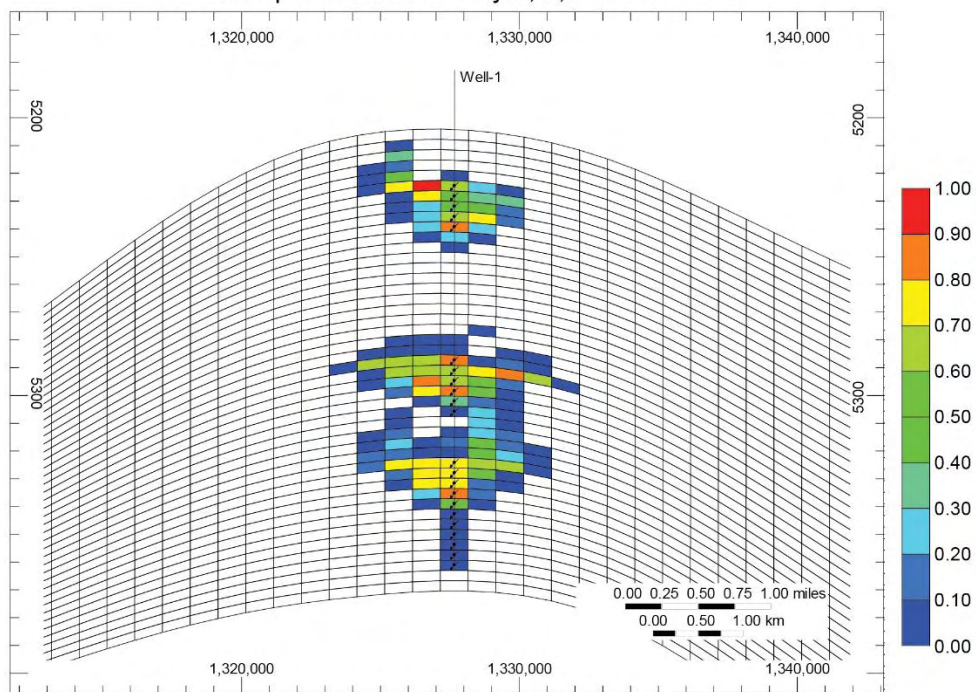

(c)

EERC BK55611.AI

Gas per Unit Area – Total, ft, 2021-01-01

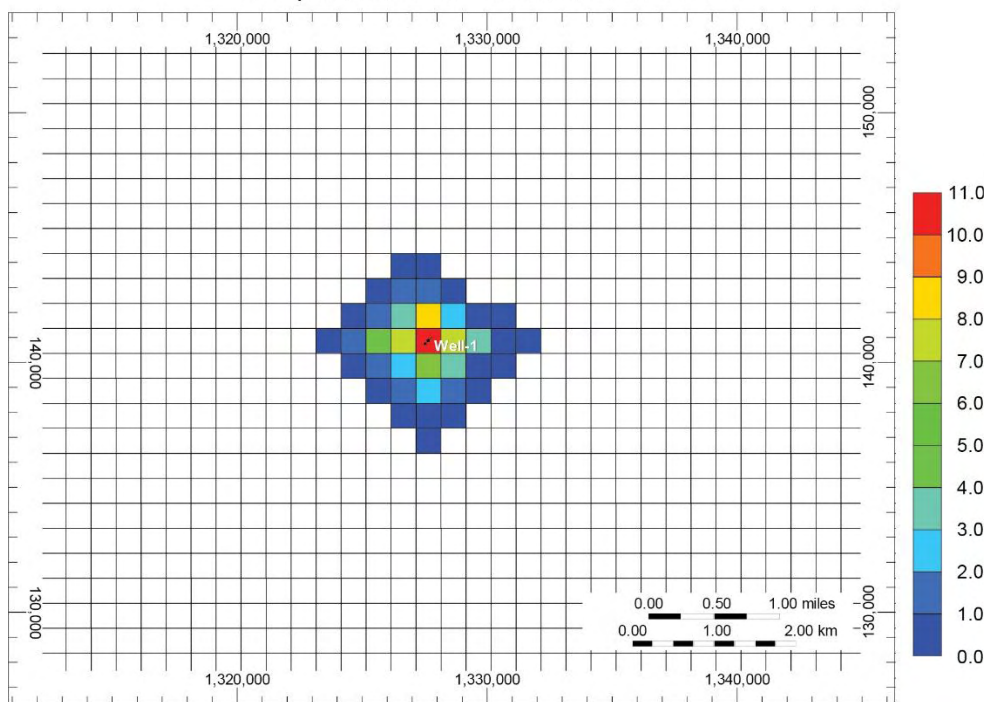

(d)

EERC BK55612.AI

Figure A-17 (continued). Cross-sectional and aerial views of the predicted gas plume extents following 2 years of injection at 10 MMscf/day (top a and b) and 30 MMscf/day (bottom c and d). The vertical exaggeration in image “a” is 75×.

As mentioned earlier, both wells in the simulation model were completed in all of the sandstone intervals penetrated by the wellbores. Additional scenarios were developed with completion intervals limited to the top 80 ft of the model to evaluate the effects of a limited perforation interval on gas injectivity and recovery, summarized in Table A-6.

Table A-6. Simulation Scenarios for Evaluating Perforation Impact (only top 80 feet of injection well perforated)

Case ID	Injection Rate	Injection Time	Gas Withdrawal after Injection	Gas Recovery Factor after 1 year of Production (Well 1; Well 2)	Gas Recovery Factor after 2 years of Production (Well 1; Well 2)	Gas Recovery Factor after 5 years of Production (Well 1; Well 2)
14	10 MMscf/day	2 years	Immediate	37%; 38%	44%; 44%	51%; 50%
15			1 year	35%; 37%	42%; 42%	49%; 48%
16			3 years	33%; 33%	40%; 37%	47%; 44%
17			5 years	31%; 29%	38%; 24%	45%; 42%

As shown in Table A-6 and Figure A-18, Cases 14–17 yielded lower gas recovery compared to Cases 6–9. This is because thinner injection intervals resulted in gas migration further from the wellbore and increased difficulty in retrieving gas at greater distance from the wells. However, in practice, drilling and completion costs would be reduced when perforating shorter intervals in wells instead of long perforations and/or perforating multiple intervals. Figure A-19 shows the plume development for the well with only the top 80 feet perforated after 2 years of injection at 10 MMscf/day. Plume size is expected to be 7000 ft in diameter. The thin perforation interval limits the injection for the 30-MMscf/day case because the injection BHP exceeds the maximum allowable pressure, causing well shut-ins to prevent further pressure increase.

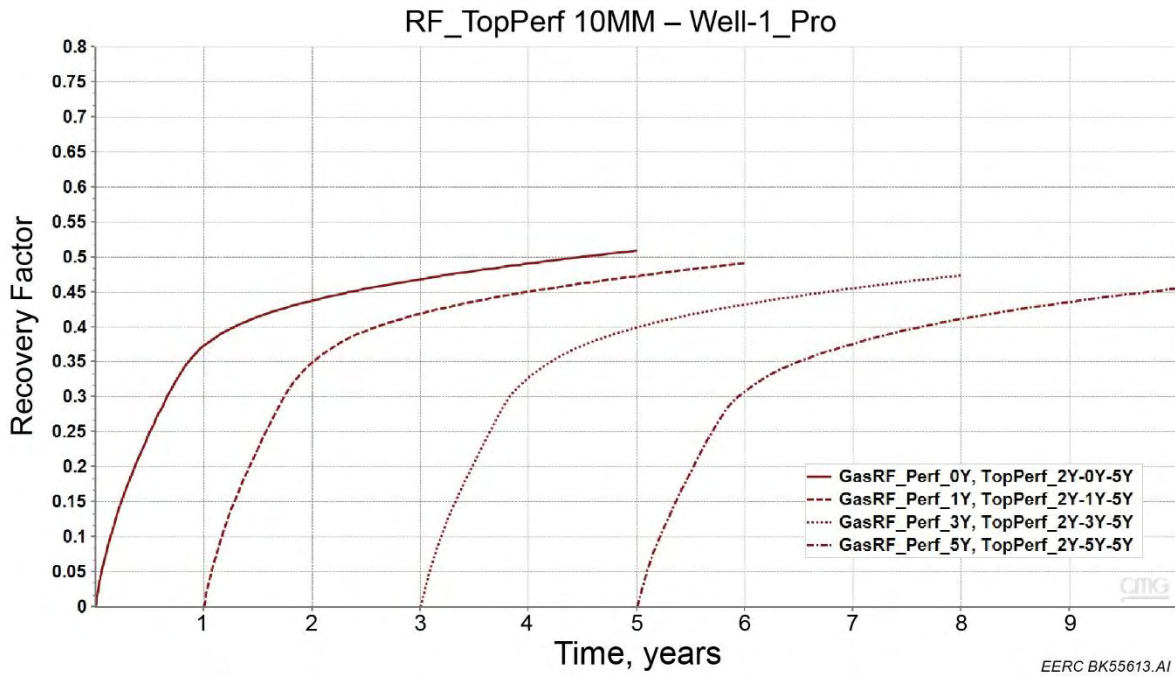
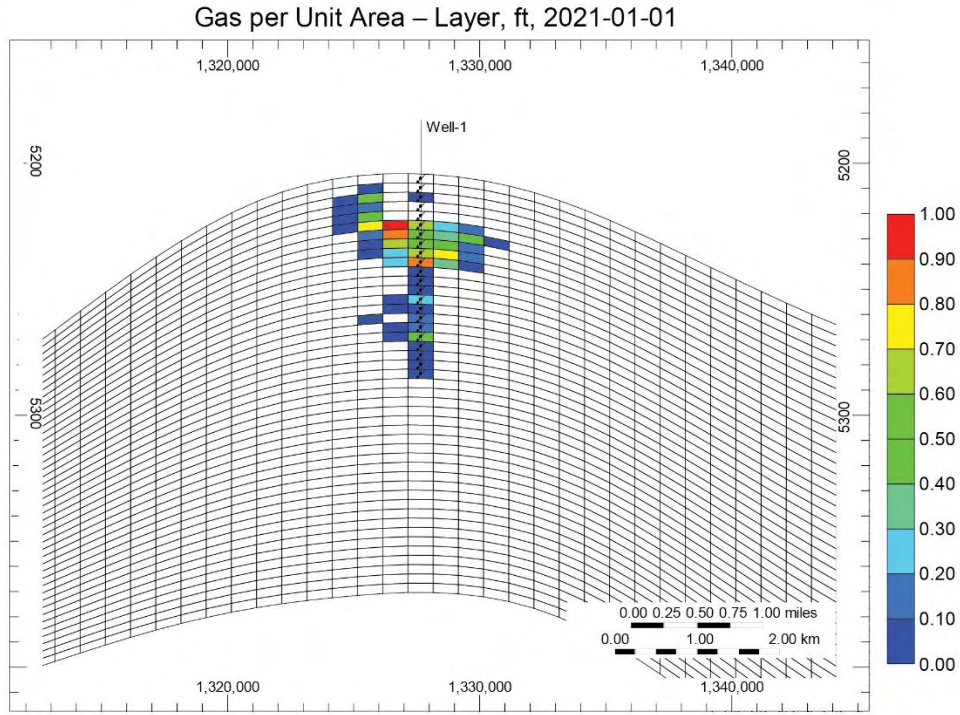
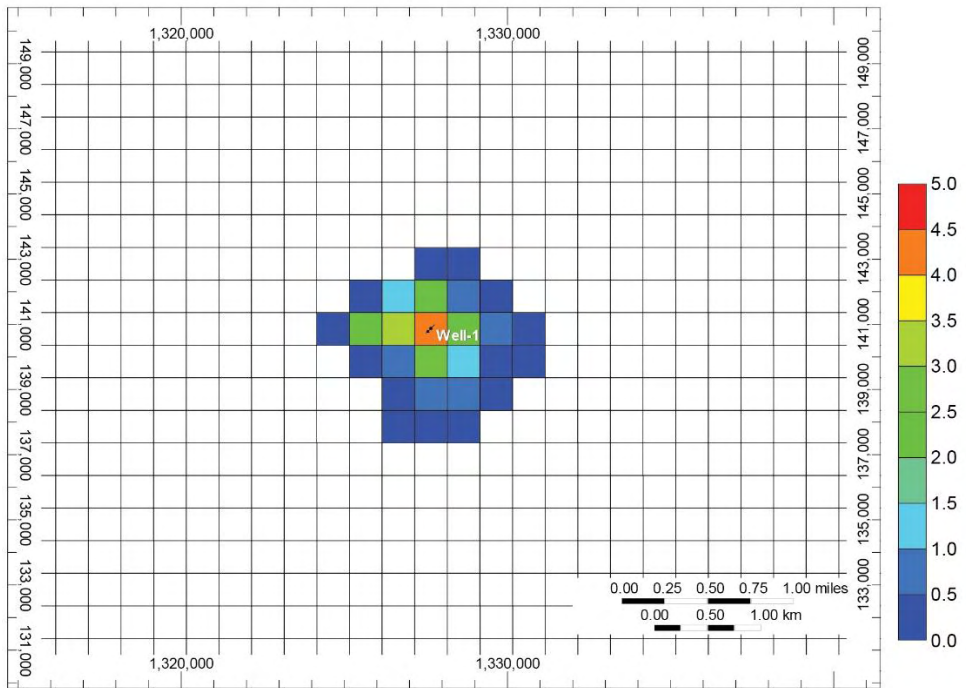

Figure A-18. Gas recovery factor for 2 years of injection at 10 MMscf/day, top 80 ft perforated wells.



(a)

EERC BK55614.AI



(b)

EERC BK55615.AI

Figure A-19. Cross-sectional and aerial views of gas plumes for well with only top 80 ft perforated following 2 years of injection at 10 MMscf/day (a and b). The vertical exaggeration in image “a” is 75 \times .

A sensitivity analysis was performed using CMG’s CMOST AI, an artificial intelligence tool powered by machine learning algorithms designed to assist in performing history matching and optimization. Case 14 was selected as a base case for this effort. Parameters were specified for the evaluation, including maximum water extraction rate, effective tubing radius, reservoir compressibility, native brine salinity, connate water/gas saturation, critical water/gas saturation (Swcrit/Sgcrit), irreducible water/gas saturation (Swcon/Sgcon), and maximum water/gas relative permeability (Krwcl/Krgcl).

The sensitivity analysis showed that critical gas saturation, which is the minimum saturation that allows gas to start flowing in reservoir, has the greatest effect on gas recovery (Figure A-20). Typical critical gas saturations in reservoirs can range from 0% to 20% (Schneider and Owens, 1970; Clossman, 1987). As shown in Figure A-20, water extraction rate, native brine water salinity, critical water saturation, and irreducible water saturation also impact gas recovery.

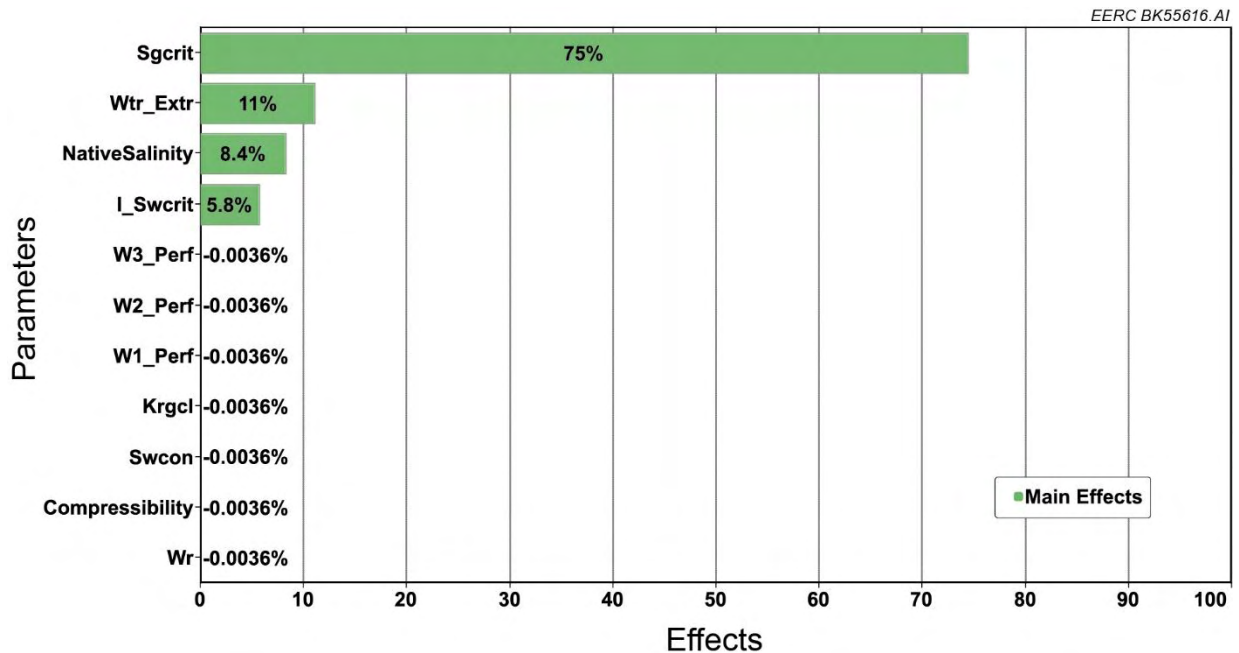

Figure A-20. Sensitivity analysis results showing the ranking of each impacting parameter.

Because of the potential effects that critical gas and water saturations can have on simulated gas recovery factors, new sets of relative permeability curves with different critical gas/water endpoints were generated and implemented in the simulation model for additional case studies to evaluate the possible range of gas recovery factors. The results of these simulation cases (18–21) are summarized in Table A-7.

Table A-7. Simulation Scenarios for Evaluating Critical Saturation Endpoints

Case ID	Injection Rate	Gas Withdrawal after 2 years of Injection	Critical Saturation Endpoint	Gas Recovery Factor after 1 year of Production (Well 1; Well 2)	Gas Recovery Factor after 2 years of Production (Well 1; Well 2)	Gas Recovery Factor after 5 years of Production (Well 1; Well 2)
18	10 MMscf/day	Immediate	Swcrit=0.2; Sgcrit=0.0	52%; 42%	58%; 47%	66%; 55%
19			Swcrit=0.2; Sgcrit=0.15	36%; 26%	39%; 29%	43%; 33%
20			Swcrit=0.5; Sgcrit=0.0	47%; 43%	51%; 47%	58%; 55%
21			Swcrit=0.5; Sgcrit=0.15	26%; 25%	29%; 27%	31%; 29%

The simulation results showed that increasing critical gas saturation could decrease recovery factor by approximately 21% (Table A-7, Figure A-21), which agrees with the proxy model from sensitivity analysis. The water/gas production plot (Figure A-22) shows that higher critical water saturation would result in generally higher water production, as this would limit the amount of gas able to accumulate in the near-wellbore environment (more lateral gas migration would be expected). Because the Broom Creek Formation is a water-wet saline formation, relatively higher critical water saturation may be expected.

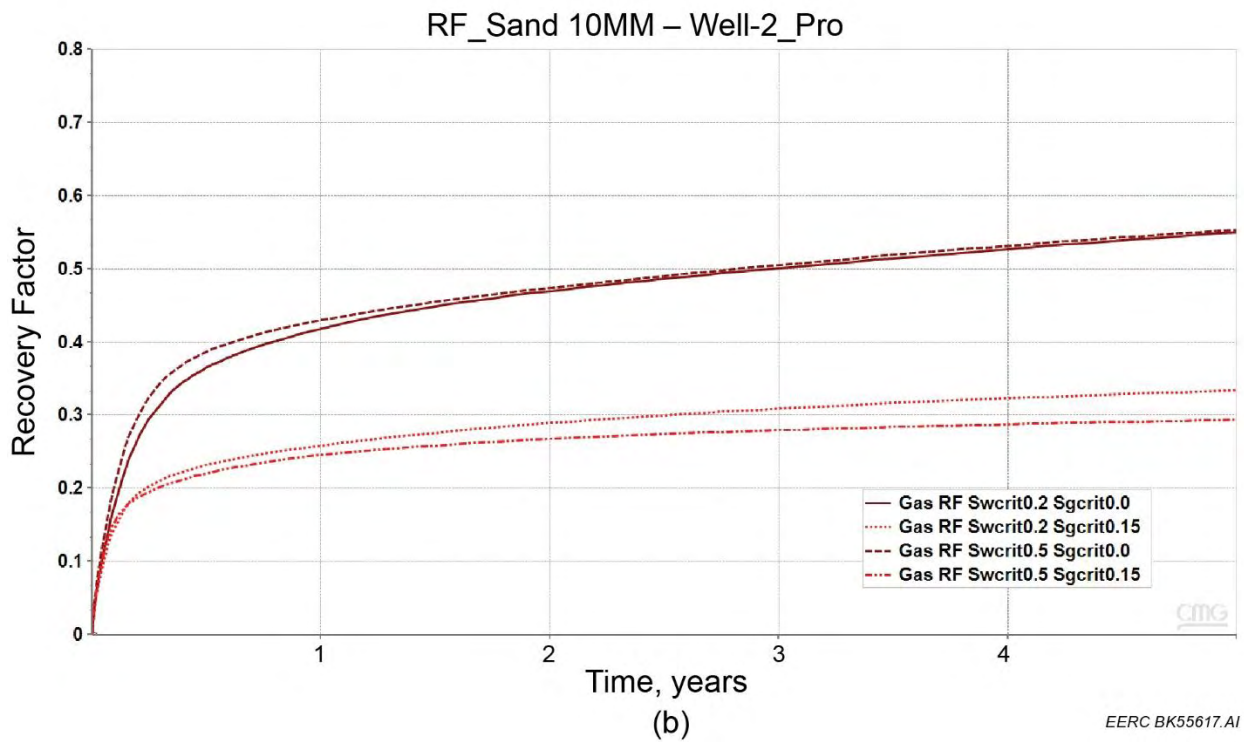
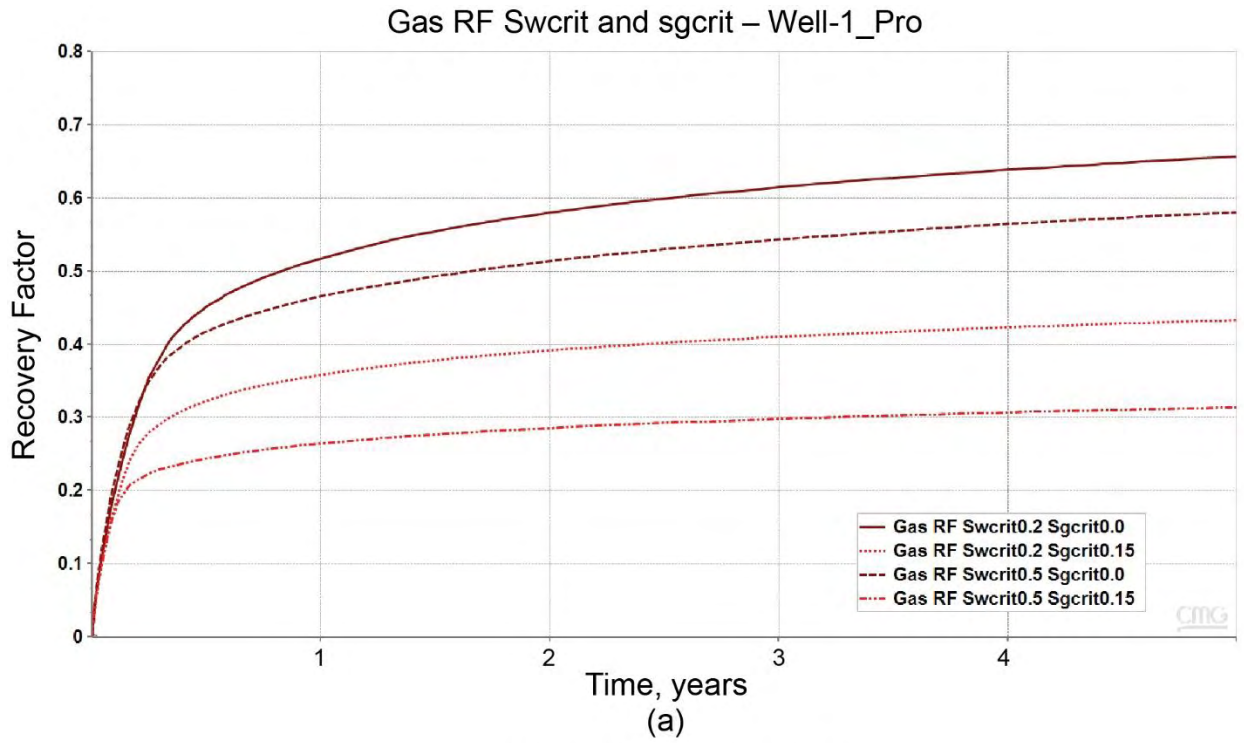
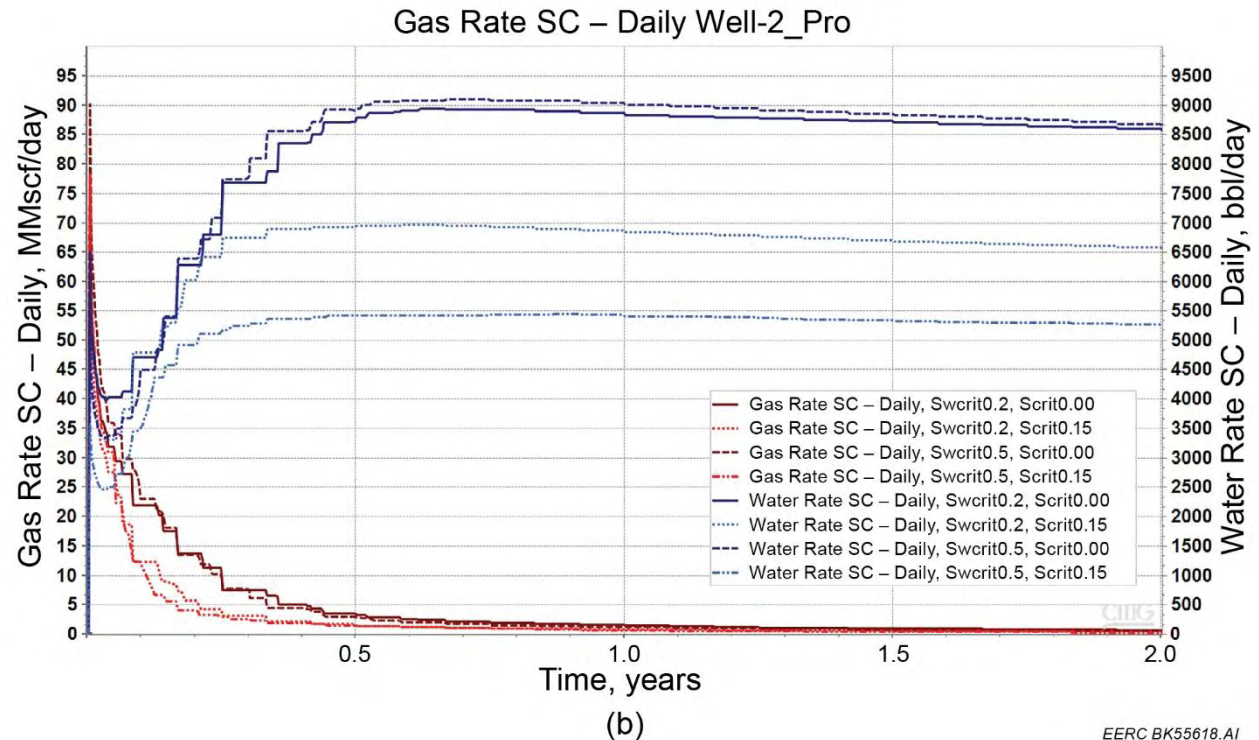
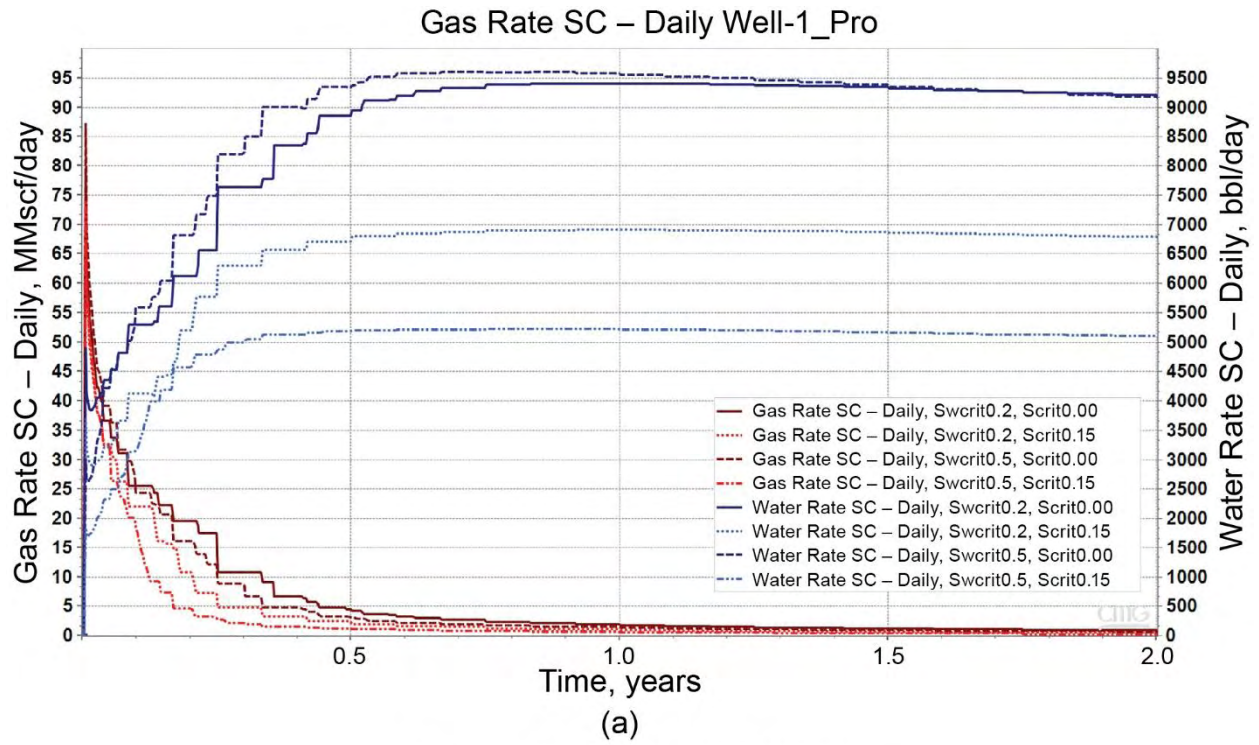

Figure A-21. Well 1 (a) and Well 2 (b) recovery factors for Cases 18–21 (injection rate of 10 MMscf/day for 2 years; immediate recovery).



EERC BK55618.A1

Figure A-22. Well 1 (a) and Well 2 (b) water and gas production rate for Cases 18–21 (injection rate of 10 MMscf/day for 2 years; immediate recovery).

As shown in Figure A-22 (and seen in previous simulation cases), the simulation results suggested that with immediate recovery, initial gas production rates could reach 90 MMscf/day (with a gas injection rate of 10 MMscf/day) and may exceed infrastructure capacity available at an individual well pad, which could range from 1 to 10 MMscf/day. Therefore, an additional series of simulation scenarios, summarized in Table A-8, were developed with varying gas production rate constraints.

Table A-8. Simulation Scenarios for Cases Constraining Gas Production Rate

Case ID	Injection Rate	Gas Withdrawal after Injection	Gas Production Constraint	Gas	Gas	Gas
				Recovery Factor after 1 year of Production (Well 1; Well 2)	Recovery Factor after 2 years of Production (Well 1; Well 2)	Recovery Factor after 5 years of Production (Well 1; Well 2)
22	10 MMscf/day	Immediate	1 MMscf/day	5%; 5%	10%; 10%	25%; 25%
23			2 MMscf/day	10%; 10%	20%; 20%	47%; 47%
24			10 MMscf/day	43%; 43%	51%; 49%	58%; 57%

The gas recovery factors after 5 years of production for Cases 22–24 are shown in Table A-8 and Figure A-23. In these simulation cases, there are no differences between Wells 1 and 2, with constrained recovery rates of 1 and 2 MMscf/day, and very little difference in recovery rates between wells for the 10-MMscf/day gas production rate. This suggests that in these cases, the effects of structure on gas recovery rates are insignificant.

Figure A-24 shows that constraining the gas production rate at 1 and 2 MMscf/day would result in a fairly constant gas production rate and significantly reduced water production rates. If production was limited to 1 MMscf/day, the simulation results suggest that the water production rate would not exceed 200 bbl/day. Limiting production to 2 MMscf/day resulted in an estimated water production rate of less than 500 bbl/day for the first 3.5 years, followed by an increase approaching 2700 bbl/day nearing the 5th year.

Although the case where gas production is constrained to 10 MMscf/day resulted in a much higher water production rate, it also had the highest recovery factor. Plus the majority (88%) of the recoverable gas (based on the volume recovered after 5 years of production) was produced after 2 years of recovery, suggesting that there could be options to optimize the economics of the operation by limiting the duration of gas recovery. Because water production increases as gas production decreases, limiting the gas recovery operation to approximately 2 years would also decrease costs associated with produced water handling and disposal. Figure A-25 illustrates the cross-sectional and aerial extent of the simulated gas plume for Wells 1 after 2 years of injection at a rate of 10 MMscf/day (Case 24). The expected plume size is 9000 ft in diameter. The increased size compared to previous cases (shown in Figure A-19) is caused by the changes made to the relative permeability parameters for these simulation cases.

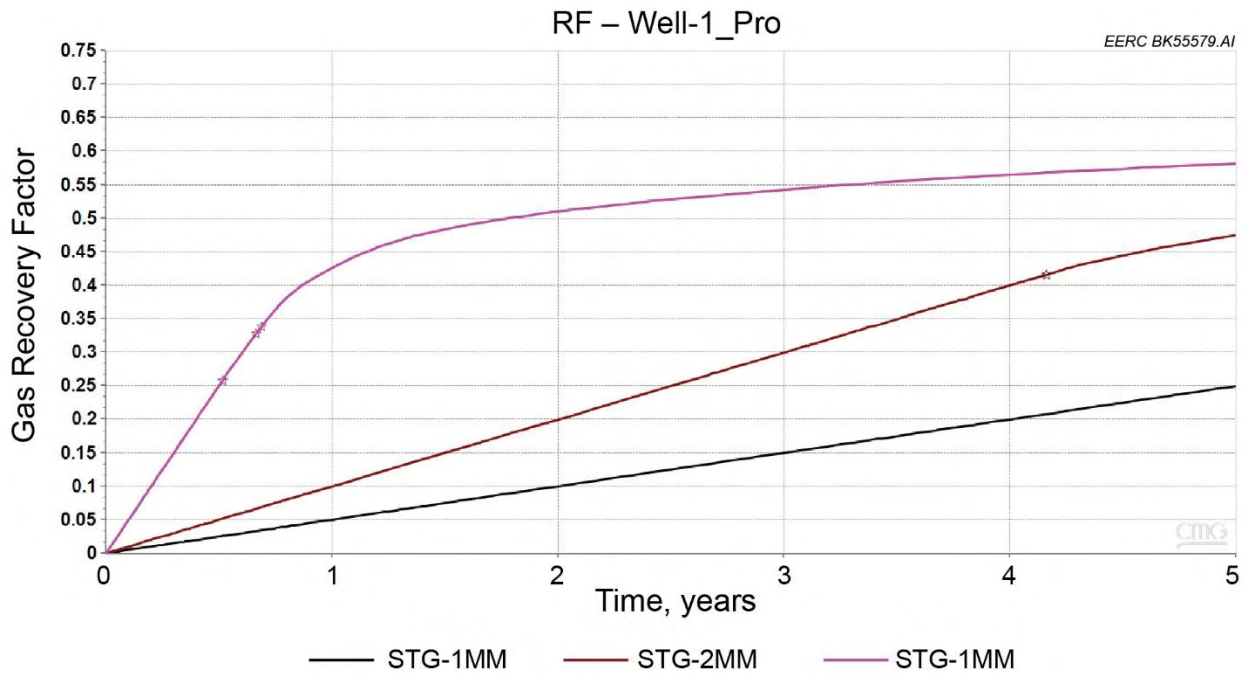

Figure A-23. Gas recovery factor for Cases 22–24.

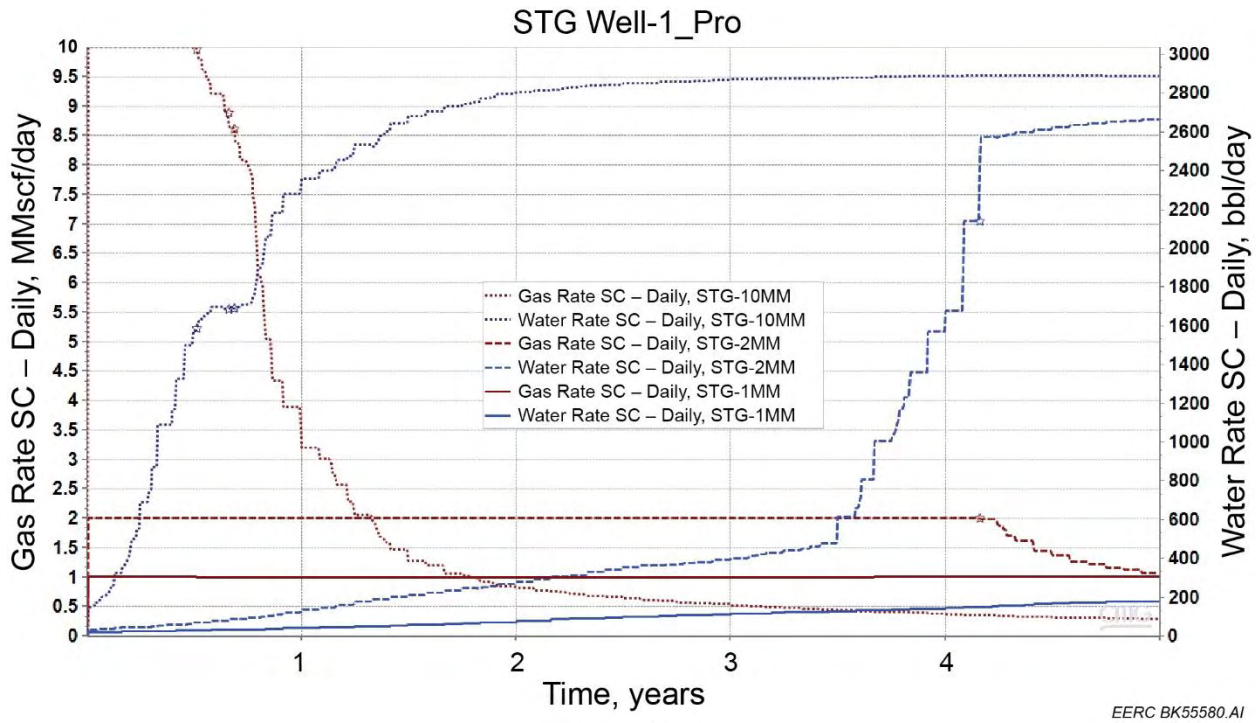
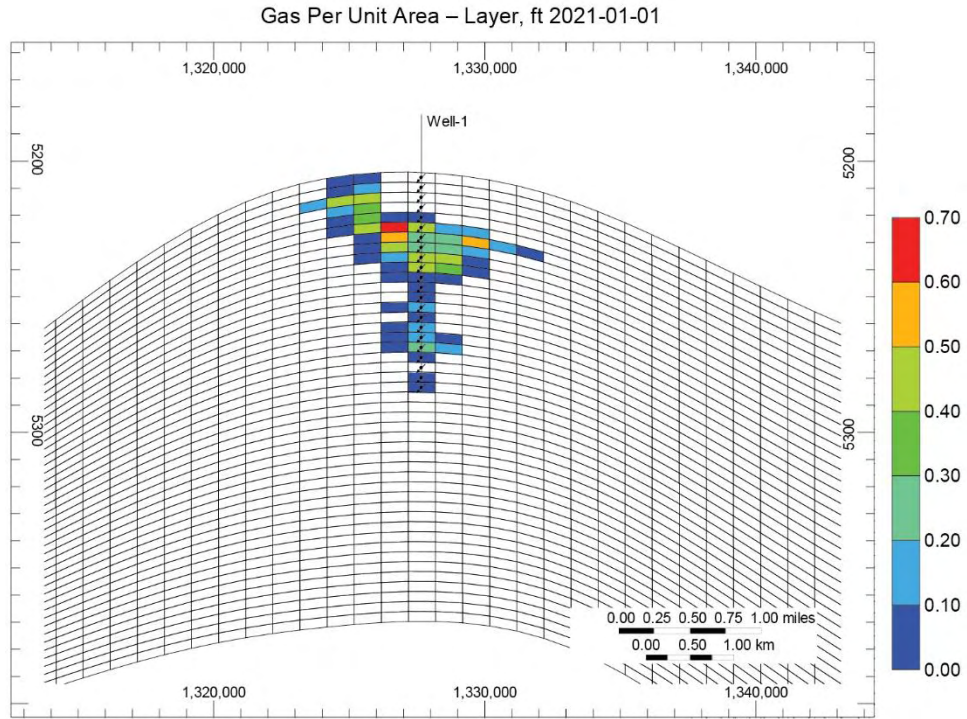
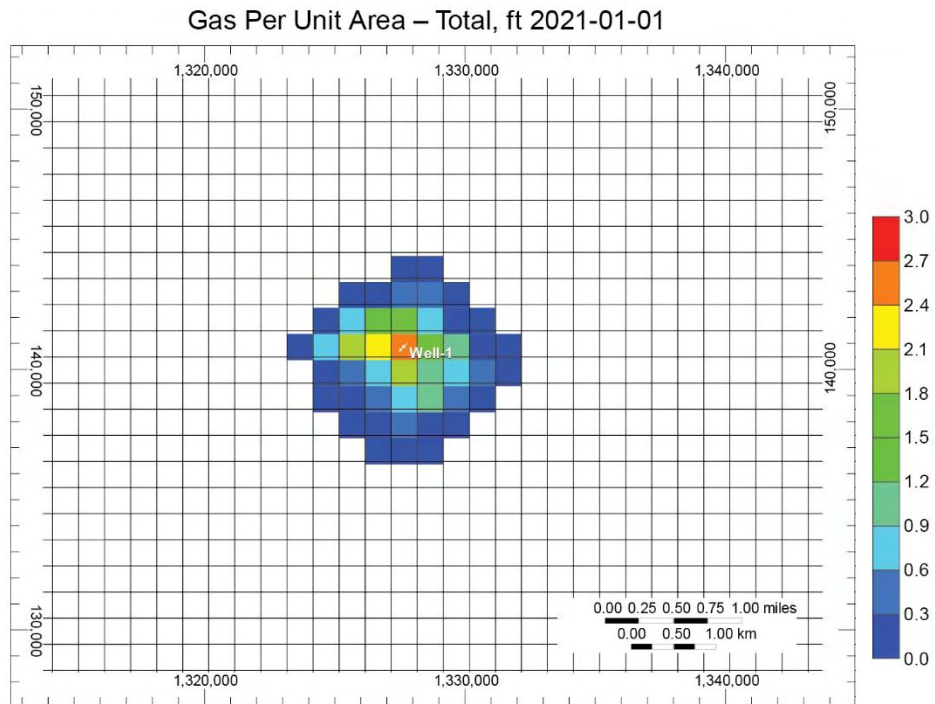

Figure A-24. Water and gas production rates from Well 1 for Cases 22–24.



(a)

EERC BK55581.AI



(b)

EERC BK55582.AI

Figure A-25. Cross-sectional view (a) and aerial view (b) of the simulated gas plume after 2 years of injection. The vertical exaggeration in image “a” is 75 \times .

One final injection scenario was evaluated to simulate a case where a well pad has been partially developed (i.e., five wells developed out of 20 planned); however, the drilling and completion of new wells on the pad has been delayed until sufficient gas-gathering capacity exists at the site. Rather than wait for pipeline capacity to become available, an operator could decide to implement a subsurface gas storage operation at the site so that the excess (uncaptured) gas from new wells could be injected rather than flared. The scenario assumed that five new wells would come online at a time for a total of three cycles, with 4 years in between each batch of well development. Once each batch of five wells comes online, the produced gas that cannot be conveyed in the existing gas capture infrastructure would be injected into the Broom Creek for 2 years at an assumed rate of 10 MMscf/day. After 2 years of injection, the gas would be recovered for a period of 2 years and conveyed off-site by the gas capture infrastructure. The assumption is that with 4 years between each development cycle, the gas production from the existing wells on-site should decline enough to free up significant additional capacity in the pipeline infrastructure. In a real-world case, the actual rates of gas injection and recovery would likely be variable over the 2-year injection and recovery period based on how much gas is produced from the new wells, the existing wells, and the available pipeline capacity.

The results of this scenario are shown in Figure A-26. With each subsequent gas recovery period, the gas recovery rate remains at 10MMscf/day for a longer period of time, the water recovery rate decreases, and the overall gas recovery factor increases. As mentioned in the literature describing commercial-scale gas storage projects, this is likely because after the initial gas injection operation, less gas is needed to establish a gas cushion in the reservoir for each subsequent injection operation. This allows for increased gas recovery during each subsequent cycle.

One of the key benefits of a cyclic approach to gas injection and recovery is that reuse of the same location for gas injection allows the cost for development of the surface facilities (compression, gas, and SWD wells) to be spread out over three gas injection and recovery operations (as opposed to just one). In addition, this approach could significantly shorten the period of time needed to fully develop all of the planned wells on a pad by providing a mechanism to store excess gas. This gas storage reservoir also allows the producer to better handle fluctuations in wellsite gas production and/or pipeline capacity upsets.

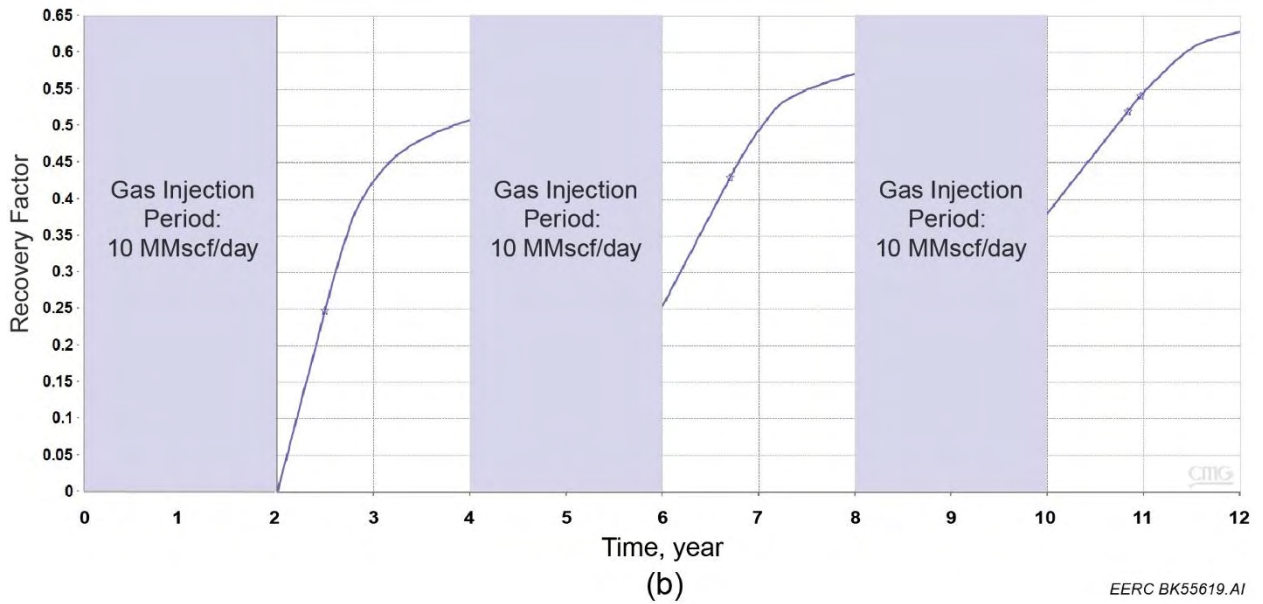
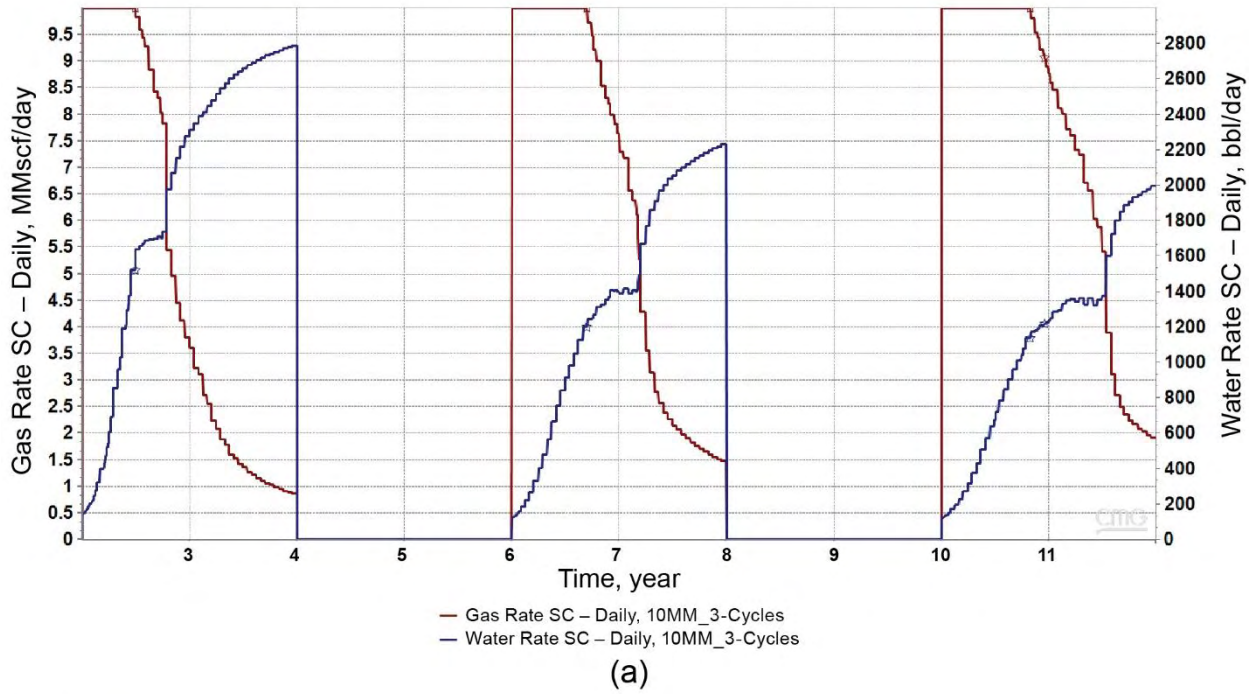

Figure A-26. Gas/water rate (a) and gas recovery factor (b), three cycles of operation.

SUMMARY OF SIMULATION RESULTS

To bracket the various operational conditions that might be encountered in the field, several simulation scenarios were evaluated, including two different injection rates (10 and 30 MMscf/day), two different injection periods (6 months and 2 years), and multiple recovery periods (immediate recovery and recovery after 1, 3, and 5 years). In addition, because the simulation results highlighted the potential issues that could occur with respect to both gas and water production rates, additional simulation cases were evaluated. These cases included the effects of various gas production constraints (1, 2, and 10 MMscf/day) and limiting water production to no more than 10,000 bbl/day. Finally, a scenario evaluating the use of a storage site for cyclic gas injection and recovery was evaluated.

A table summarizing each of the simulation cases and the predicted recovery factor after 1, 2, and 5 years of production is included in Table A-9. Recovery factors generated from the various simulation cases (excluding the initial simulation, Case 1) ranged from a low of 25% to a high of 74% after 5 years of gas recovery from Well 1 and a low of 25% and a high of 64% in Well 2. In each batch of simulation cases, the highest gas recovery rates were seen with gas injection for 6 months or 2 years, followed by immediate recovery. As would be expected, the lowest recovery factors were seen in the cases where gas production rates were limited to 1 and 2 MMscf/day. If these two cases are excluded, then the lowest gas recovery rates after 5 years of production were 31% and 29% for Wells 1 and 2, respectively. The simulation results suggested that when not constraining the gas production rate at a lower level (1 or 2 MMscf/day), on average, approximately 90% of the recoverable gas (based on a 5-year recovery period) is retrieved after 24 months of production.

Water production rates typically increase dramatically within the first 6 to 12 months of production; thus from an operational and economic standpoint, the simulation results suggest that shorter gas recovery periods may be more realistic. Otherwise, water production and associated handling costs increase dramatically with little additional gas recovery. The case involving cyclic gas injection and recovery suggested that water production rates decrease significantly after each subsequent cycle with increasing gas recovery factors.

In almost all cases, significant differences in recovery were seen between Wells 1 and 2, with Well 1 exhibiting higher recovery factors than Well 2. As expected, this indicates that sites with geologic structure to help contain gas and fluid movement will likely result in higher gas recovery factors. Site-specific characterization and reservoir simulation efforts would be needed to better define the gas injectivity and recovery performance for individual sites.

Constraining gas production to 1 to 2 MMscf/day significantly reduced water production, at the cost of longer gas recovery periods and lower gas recovery factors. A constrained gas production rate of 10 MMscf/day resulted in improved gas recovery but also larger water production rates. Ultimately, in any gas storage project, the site-specific conditions will need to be evaluated and the balance between gas recovery rates and volumes will need to be balanced with the available gas pipeline capacity and operational costs of the site, including water handling and disposal.

Table A-9. Complete Summary of Each Simulation Case and the Predicted Recovery Factor after 1, 2, and 5 years of Production

Case ID	Injection Rate	Injection Time	Gas Withdrawal after Injection	Gas Recovery Factor after 1 year of Production (Well 1; Well 2)	Gas Recovery Factor after 2 years of Production (Well 1; Well 2)	Gas Recovery Factor after 5 years of Production (Well 1; Well 2)	Production Constraints	Note
1	10 MMscf/day	6 months	5 years	0%; 12%	27%; 12%	28%; 17%	n/a	Perforated all zones
2	10 MMscf/day	6 months	Immediate	53%; 44%	63%; 52%	74%; 64%	Production BHP 3500 psi (close to Pi); 10,000 bbl/day water	Only sandstone intervals perforated
3			5 years	44%; 26%	51%; 35%	61%; 49%		
4			Immediate	51%; 40%	59%; 45%	68%; 54%		
5	30 MMscf/day	6 months	5 years	42%; 28%	49%; 33%	57%; 42%		
6			Immediate	49%; 37%	56%; 44%	64%; 51%		
7			10 MMscf/day	2 years	1 year	48%; 36%		
8	3 years	45%; 31%			51%; 36%	57%; 43%		
9	5 years	40%; 28%			46%; 33%	53%; 40%		
10	30 MMscf/day	2 years	Immediate	46%; 43%	55%; 50%	63%; 57%		
11			1 year	43%; 40%	53%; 47%	61%; 54%		
12			3 years	40%; 36%	51%; 43%	58%; 51%		
13	10 MMscf/day	2 years	5 years	36%; 33%	48%; 40%	55%; 48%		
14			Immediate	37%; 38%	44%; 44%	51%; 50%		
15			1 year	35%; 37%	42%; 42%	49%; 48%		
16			3 years	33%; 33%	40; 37%	47%; 44%		
17			5 years	31%; 29%	38%; 24%	45%; 42%		
18				52%; 42%	58%; 47%	66%; 55%	Swcrit=0.2; Sgcrit=0.0	
19	10 MMscf/day	2 years	Immediate	36%; 26%	39%; 29%	43%; 33%	Swcrit=0.2; Sgcrit=0.15	
20				47%; 43%	51%; 47%	58%; 55%	Swcrit=0.5; Sgcrit=0.0	
21				26%; 25%	29%; 27%	31%; 29%	Swcrit=0.5; Sgcrit=0.15	
22				5%; 5%	10%; 10%	25%; 25%	Gas rate 1 MMscf/day	
23	10 MMscf/day	2 years	Immediate	10%; 10%	20%; 20%	47%; 47%	Gas rate 2 MMscf/day	Swcrit=0.5; Sgcrit=0.0
24				43%; 43%	51%; 49%	58%; 57%	Gas rate 10 MMscf/day	

REFERENCES

- Bennion, B., and Bachu, S., 2005, Relative permeability characteristics for supercritical CO₂ displacing water in a variety of potential sequestration zones in the Western Canada sedimentary basin, SPE 95547, SPE Annual Technical Conference and Exhibition, Dallas, Texas, October 9–12.
- Computer Modelling Group, 2018, GEM User Guide, Computer Modelling Group.
- Rygh, M.E., 1990, The Broom Creek Formation (Permian) in southwestern North Dakota: Master's thesis, University of North Dakota, Grand Forks, North Dakota, p. 189.
- Schlumberger, 2016, Petrel 2016: Petrel E&P software platform.
- Schneider, F.N., and Owens, W.W., 1970, Sandstone and carbonate two- and three-phase relative permeability characteristics: SPE Journal, p. 75–84.
- Sorensen, J.A., and Hamling, J.A., 2016, Historical Bakken test data provide critical insights on EOR in tight oil plays: The American Oil & Gas Reporter, v. 59, no. 2, p. 55–61, February.